



Standard Details

Revised March 2015

P: 206.362.8100
F: 206.361.0629

1519 NE 177th St
Shoreline, WA 98155

STANDARD DETAILS

<u>Title</u>	<u>File</u>	<u>Revised</u>	<u>Page</u>
1. Wet Tap Detail	SD#1	03/15	2
2. Fire Hydrant Straight Installation	SD#2	03/15	3
3. Fire Hydrant Offset Installation	SD#3	03/15	4
4. Fire Hydrant Bend Installation	SD#4	03/15	5
5. Type C Fire Hydrant Assembly	SD#5	03/15	6
6. Existing 1" and Smaller Service Reconnection	SD#6	03/15	7
7. 5/8"x3/4" Service with Meter Setting	SD#7	03/15	8
8. 1" Service with Meter Setting	SD#8	03/15	9
9. 1.5" Service with Meter Setting	SD#9	03/15	10
10. 2" Service with Meter Setting	SD#10	03/15	11
11. 3" and 4" Water Service	SD#11	03/15	12
12. Typical Trench Section	SD#12	03/15	13
13. Trench Surface Restoration	SD#13	03/15	14
14. 2" and Smaller Reduced Pressure Backflow Assembly	SD#14	03/15	15
15. 2.5" and Larger Reduced Pressure Backflow Assembly	SD#15	03/15	16
16. Double Check Valve Assembly 2" and smaller	SD#16	03/15	17
17. Residential PRV	SD#17	03/15	18
18. Double Check Detector Assembly	SD#18	03/15	19
19. Intentionally Left Blank	N/A	N/A	N/A
20. 1" and 2" Testing Trees	SD#20	03/15	20
21. 1" Air Valve	SD#21	03/15	21
22. 2" Air valve	SD#22	03/15	22
23. Concrete Thrust Blocking	SD#23	03/15	23
24. Valves and Restraint Requirements	SD#24	03/15	24
25. Intentionally Left Blank	N/A	N/A	N/A
26. Maximum Permissible Deflection Pressurized D.I. Pipe	SD#26	03/15	25
27. Valve Operating Nut Extension	SD#27	03/15	26
28. Meter Installation and Location	SD#28	03/15	27
29. Water and Sewer Separation	SD#29	03/15	28
30. Typical Casing Profile	SD#30	03/15	29
31. PVBA/SVBA Backflow Preventers	SD#31	03/15	30

Notes:

1) All Materials shall be Domestic made.

*With exception of 931 valve box, lid and bottom.

2) All brass shall conform to the low lead rule.

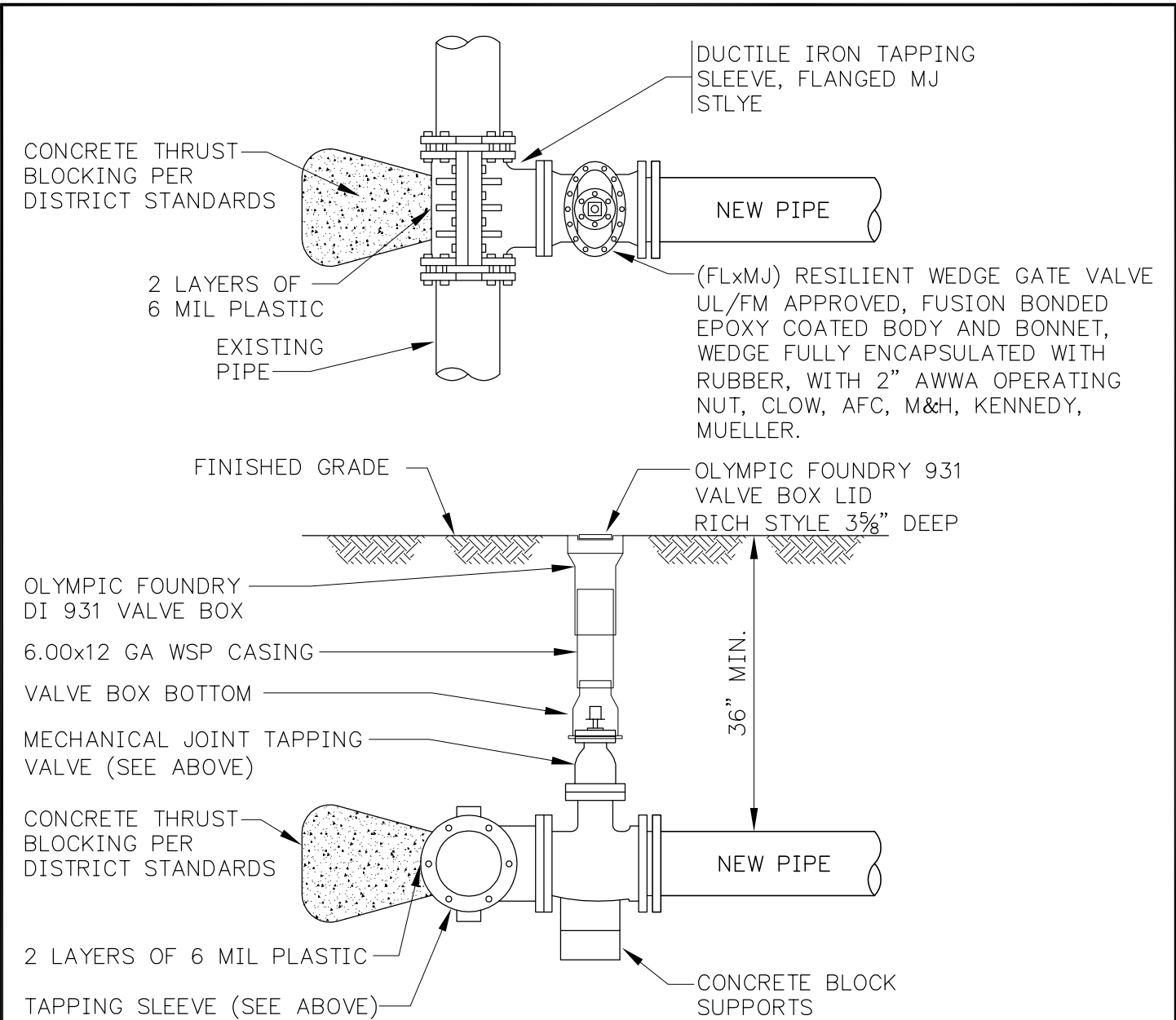

NOTES:

1. PRIOR TO BORING:
 - A. TAPPING SLEEVE AND VALVE SHALL BE STERILIZED WITH 12.5% CHLORINE PER SPECIFICATIONS.
 - B. TAPPING SLEEVE AND VALVE SHALL BE AIR TESTED AT 30 PSI FOR 5 MIN. WITH NO LOSS.

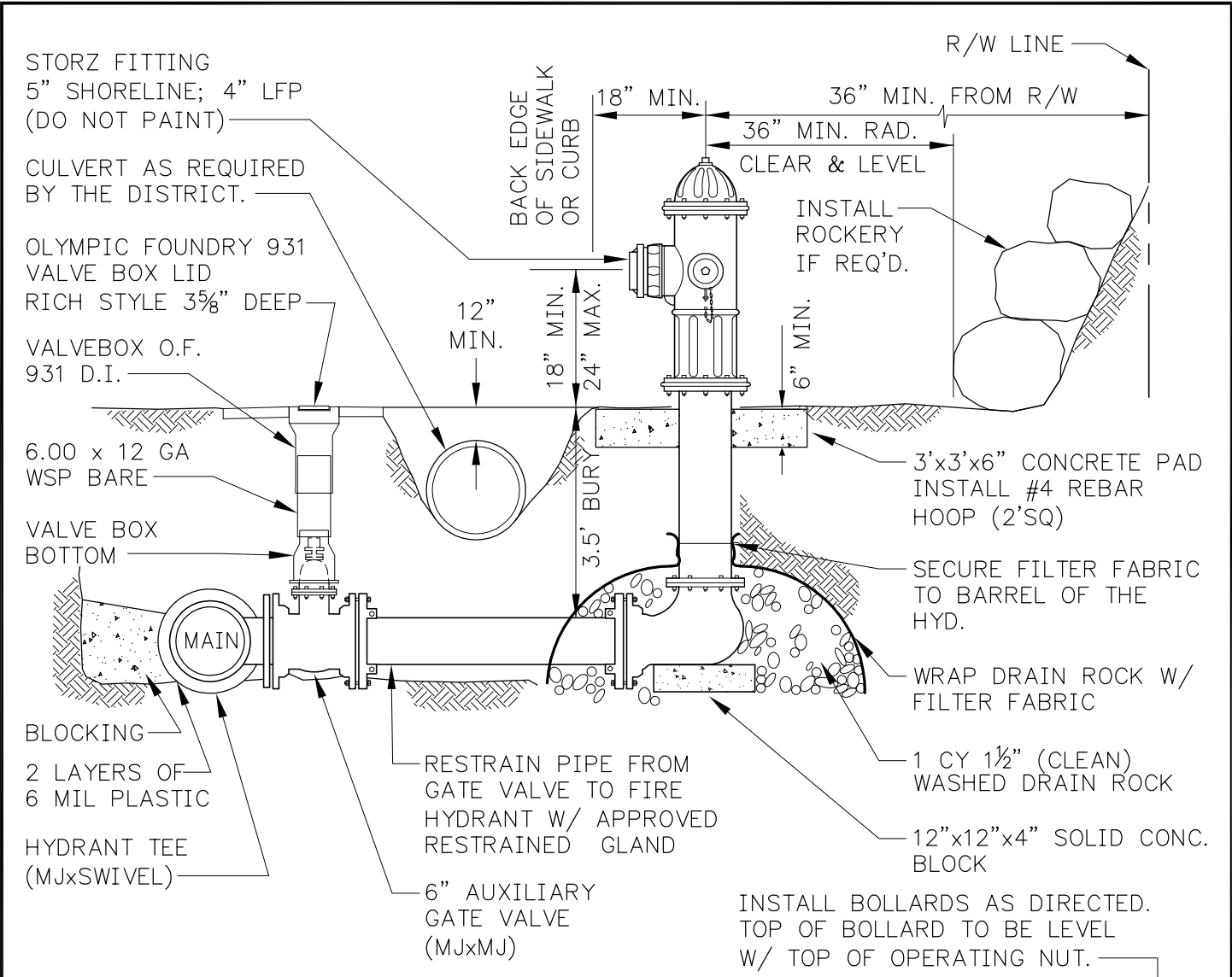

REVISED: 03/15	NCWD STANDARD DETAIL	NO. 1
	WET TAP	

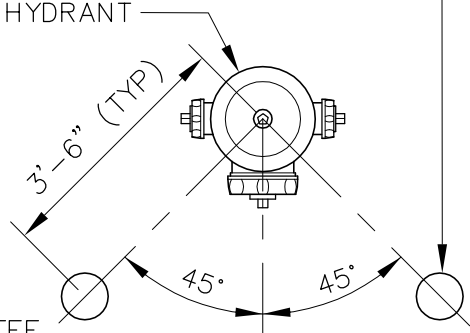

NOTES:

1. PROVIDE LEVEL ACCESS TO FIRE HYDRANT.
2. FIRE HYDRANTS & BOLLARDS TO BE PAINTED WITH (2) COATS KELLY MOORE SAFETY YELLOW ACRYLIC GLOSS ENAMEL LUXLITE Q.D. ALKYD GLOSS ENAMEL #5880-563 DTM OR PPG PITT-TECH 90-330 SAFETY YELLOW.
3. DETAIL ABOVE SHOWS NEW CONSTRUCTION HYDRANT TEE.
4. ALLOWABLE HYDRANTS: M & H-929; MUELLER A-423; AVK 2780; AMERICAN DARLING B-62-B.
5. ALL BOLTS SHALL BE TRIPAC 2000 BLUE.



REVISED: 03/15	NCWD STANDARD DETAIL	NO. 2
	FIRE HYDRANT STRAIGHT INSTALLATION	

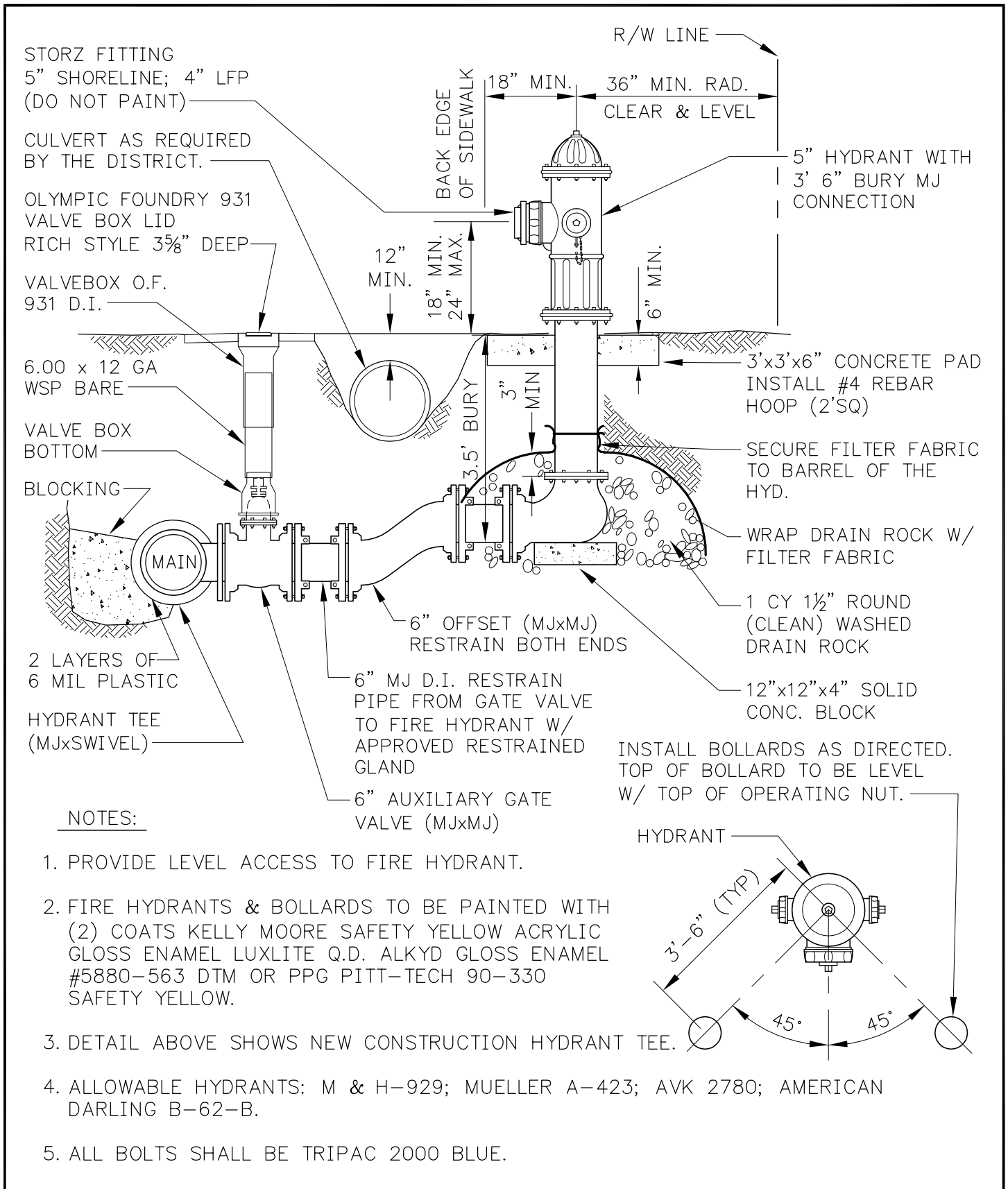

NOTES:

1. PROVIDE LEVEL ACCESS TO FIRE HYDRANT.
2. FIRE HYDRANTS & BOLLARDS TO BE PAINTED WITH (2) COATS KELLY MOORE SAFETY YELLOW ACRYLIC GLOSS ENAMEL LUXLITE Q.D. ALKYD GLOSS ENAMEL #5880-563 DTM OR PPG PITT-TECH 90-330 SAFETY YELLOW.
3. DETAIL ABOVE SHOWS NEW CONSTRUCTION HYDRANT TEE.
4. ALLOWABLE HYDRANTS: M & H-929; MUELLER A-423; AVK 2780; AMERICAN DARLING B-62-B.
5. ALL BOLTS SHALL BE TRIPAC 2000 BLUE.

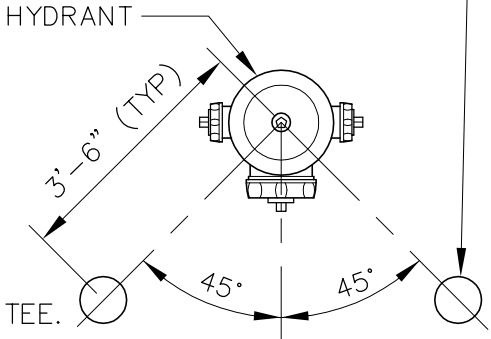

REVISED: 03/15	NCWD STANDARD DETAIL	NO. 3
	FIRE HYDRANT OFFSET INSTALLATION	

SURFACE TO BE GRADED SMOOTH AROUND HYDRANT

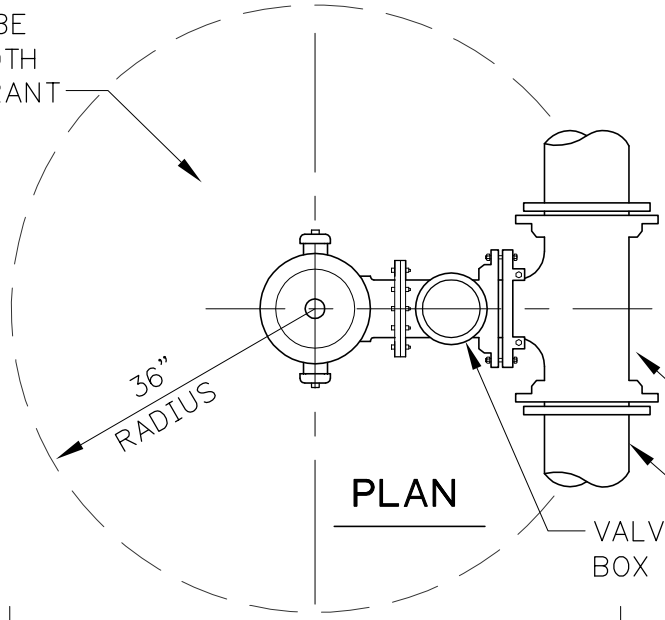

NOTES:

1. ALLOWABLE HYDRANTS: M & H-929; MUELLER A-423; AVK 2780; AMERICAN DARLING B-62-B.
2. PAINT FIRE HYDRANTS PER STANDARD DETAILS 1-4
3. ALL BOLTS SHALL BE TRIPAC 2000 BLUE.

PROPERTY LINE

36" MIN. (UNLESS DIRECTED OTHERWISE)

36" MIN. (6' MIN. FROM TRAVEL LANE)

4'x4'x6" CONCRETE PAD INSTALL #4 REBAR HOOP (2'SQ)

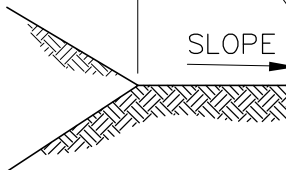

SPOOL LENGTH TO SUIT TRENCH DEPTH

FILTER FABRIC

1 CY 1 1/2" ROUND (CLEAN) WASHED DRAIN ROCK

SOLID CONCRETE BEARING BLOCK 12"x12"x4" MIN. SIZE

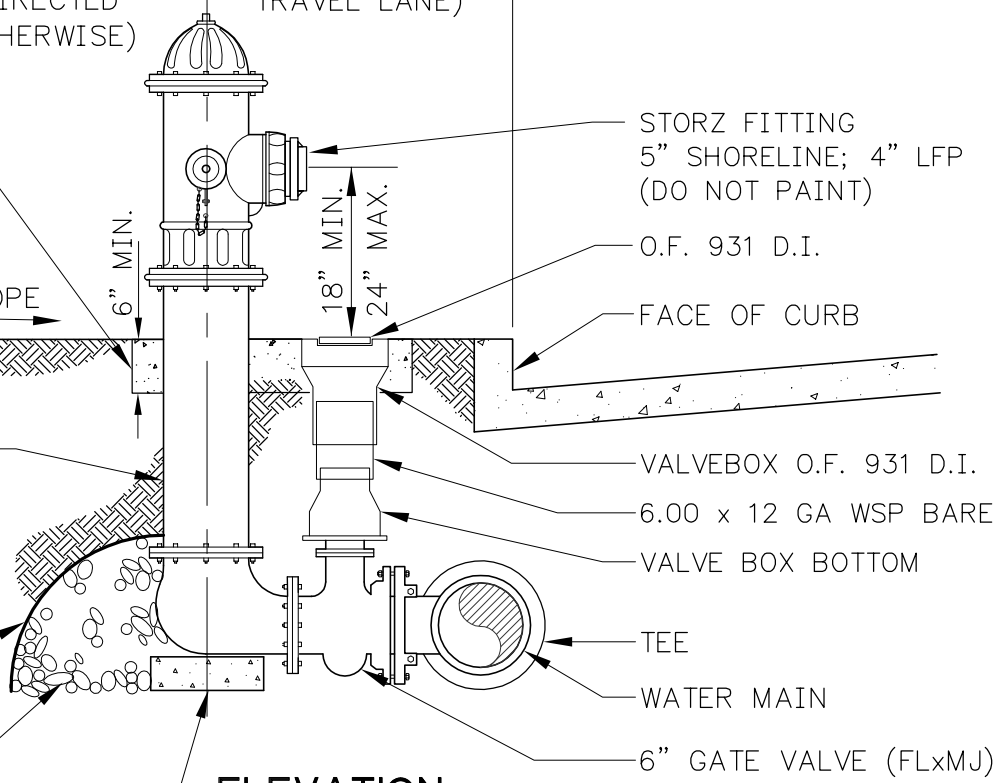

REVISED: 03/15

NCWD STANDARD DETAIL

NO. 5



FLG FIRE HYDRANT ASSEMBLY



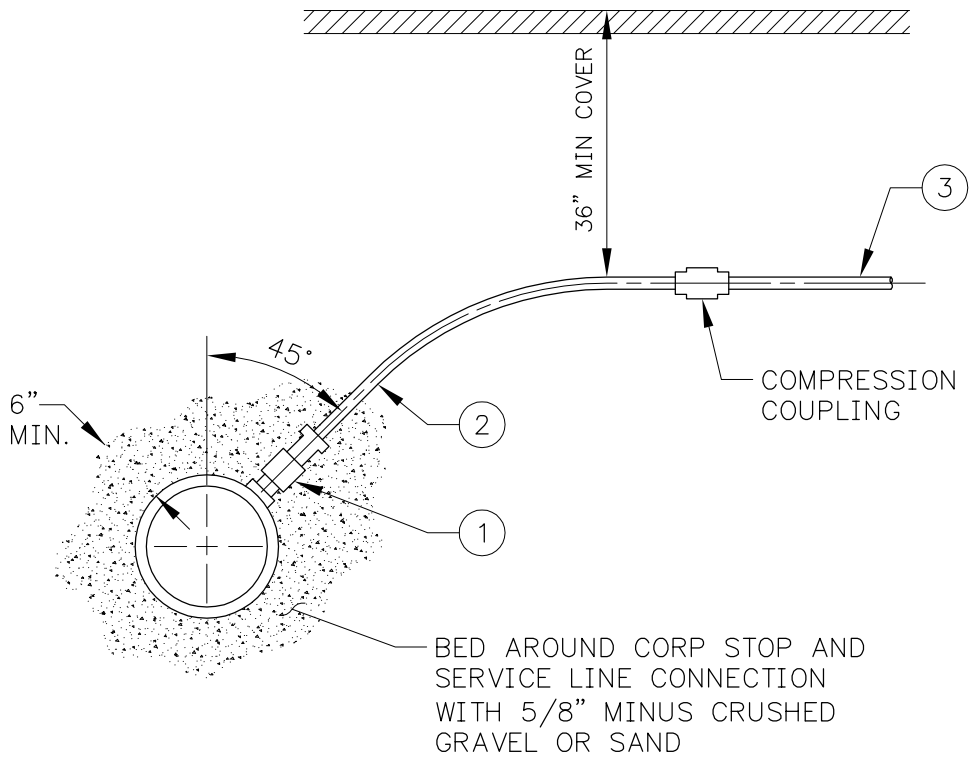

NOTES:

- ① 1" CORP STOP. AWWA COTH INLET BY COMPRESSION FITTING FOR COPPER PIPE.
- ② NEW SERVICE LINE EXTENSION – SOFT COPPER 1" TYPE K.
- ③ EXISTING SERVICE LINE IS ASSUMED TO BE COPPER. FIELD VERIFY BEFORE CONSTRUCTION.

REVISED: 03/15

NCWD STANDARD DETAIL

NO. 6



EXISTING 1" AND SMALLER SERVICE RECONNECTION



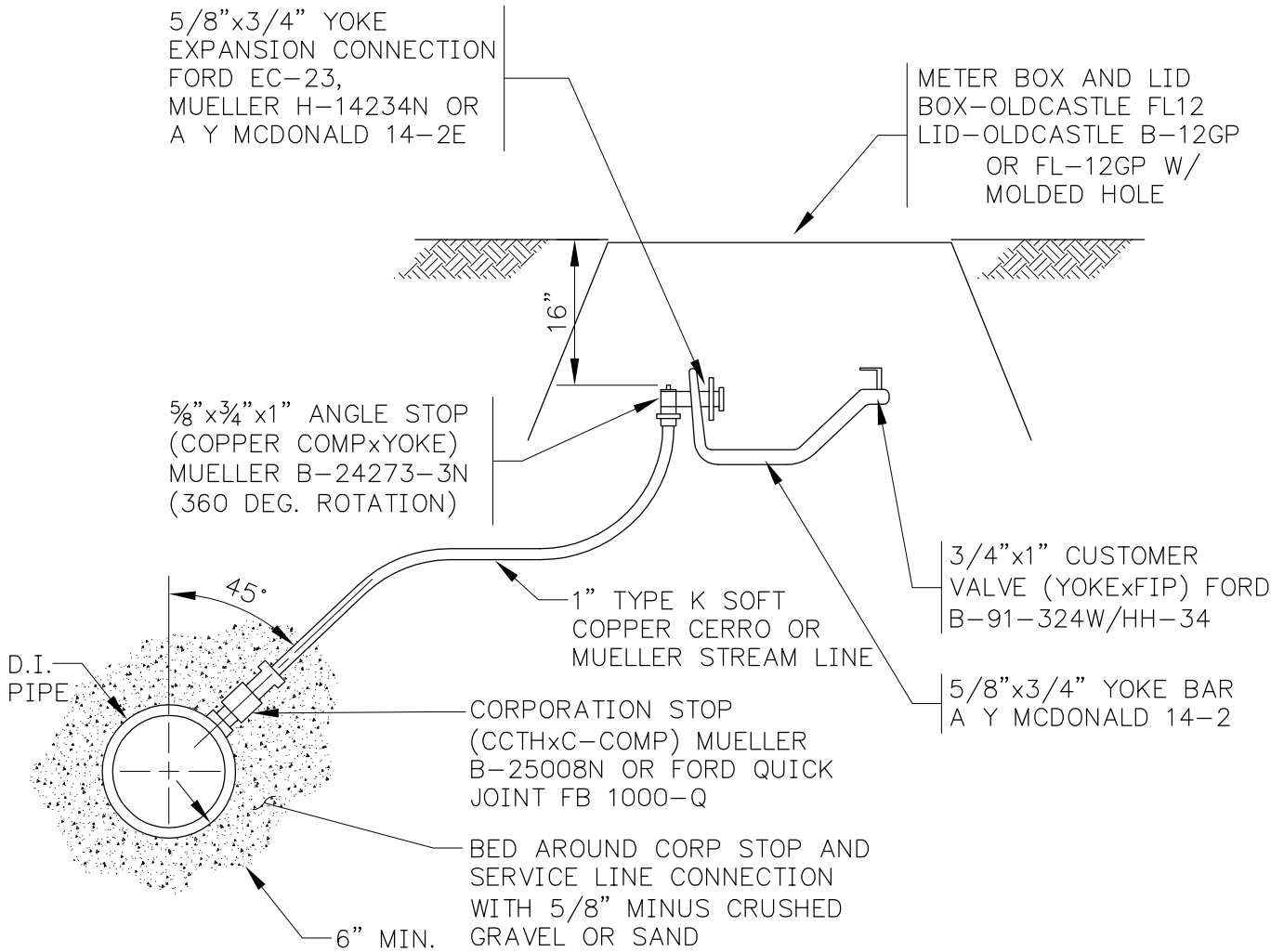

NOTES:

1. FOR RELOCATED SERVICES: CONTRACTOR SHALL PROVIDE ALL MATERIALS SHOWN ON DETAIL UNLESS OTHERWISE SPECIFIED. NCWD WILL RELOCATE METER. CONTRACTOR TO RECONNECT CUSTOMER'S SERVICE LINE.
2. FOR EXISTING SERVICES TO BE RECONNECTED TO NEW MAIN: INSTALL CORPORATION STOP.
3. ALL BRASS PARTS SHALL CONFORM TO THE NEW LOW LEAD RULE

REVISED: 03/15

NCWD STANDARD DETAIL

NO. 7



5/8" AND 3/4" SERVICE WITH METER SETTING



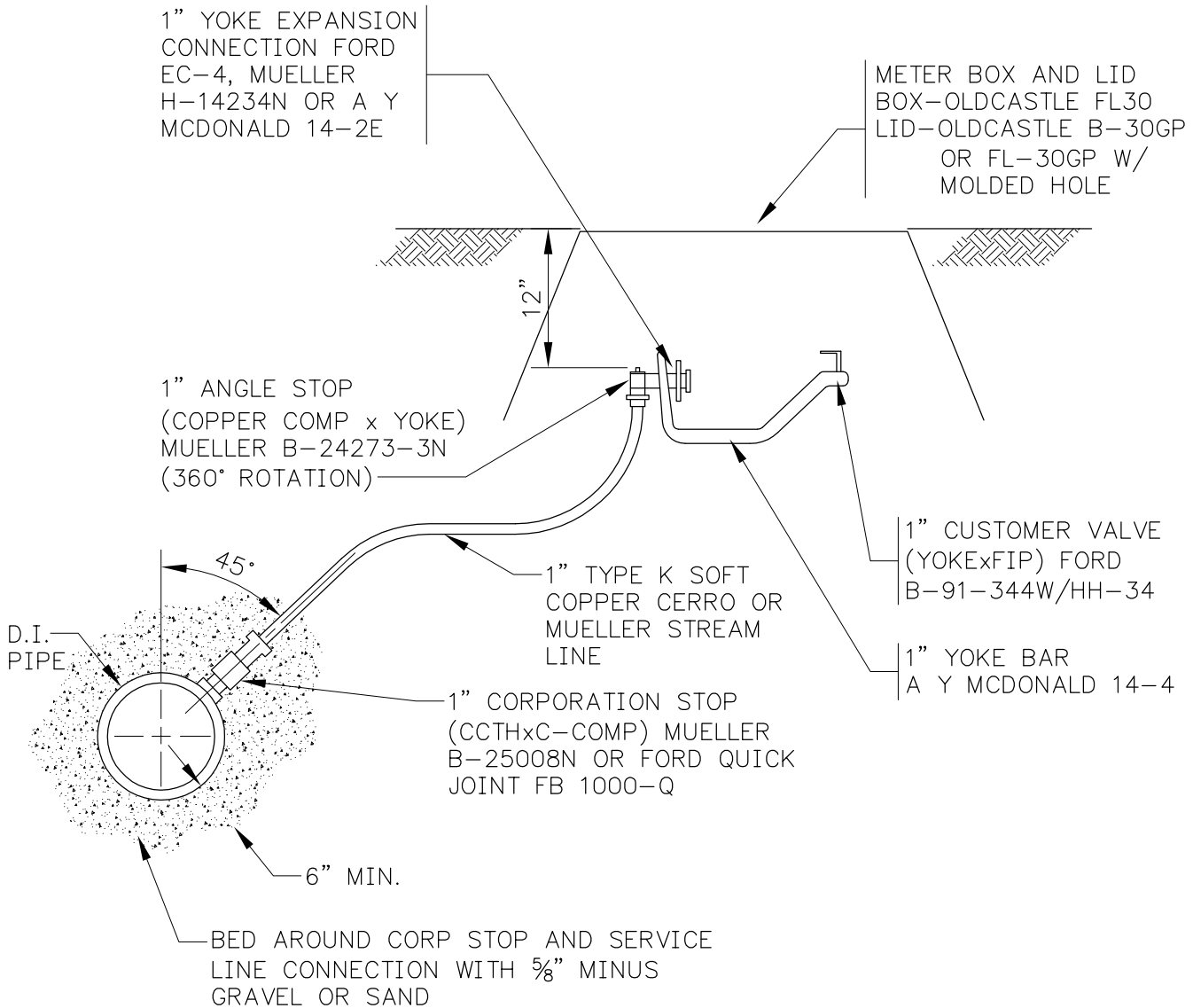

NOTES:

1. FURNISH AND INSTALL COPPER SERVICE LINE. FURNISH AND INSTALL CORPORATION AND ANGLE STOPS. FURNISH AND INSTALL YOKE BAR, CUSTOMER VALVE, METER BOX, AND LID. PROVIDE EXCAVATION AND BACKFILL.
2. FOR EXISTING SERVICES TO BE RECONNECTED TO NEW MAIN: INSTALL CORPORATION STOP.
3. ALL BRASS PARTS SHALL CONFORM TO THE NEW LOW LEAD RULE.

REVISED: 03/15

NCWD STANDARD DETAIL

NO. 8



1" SERVICE WITH METER SETTING



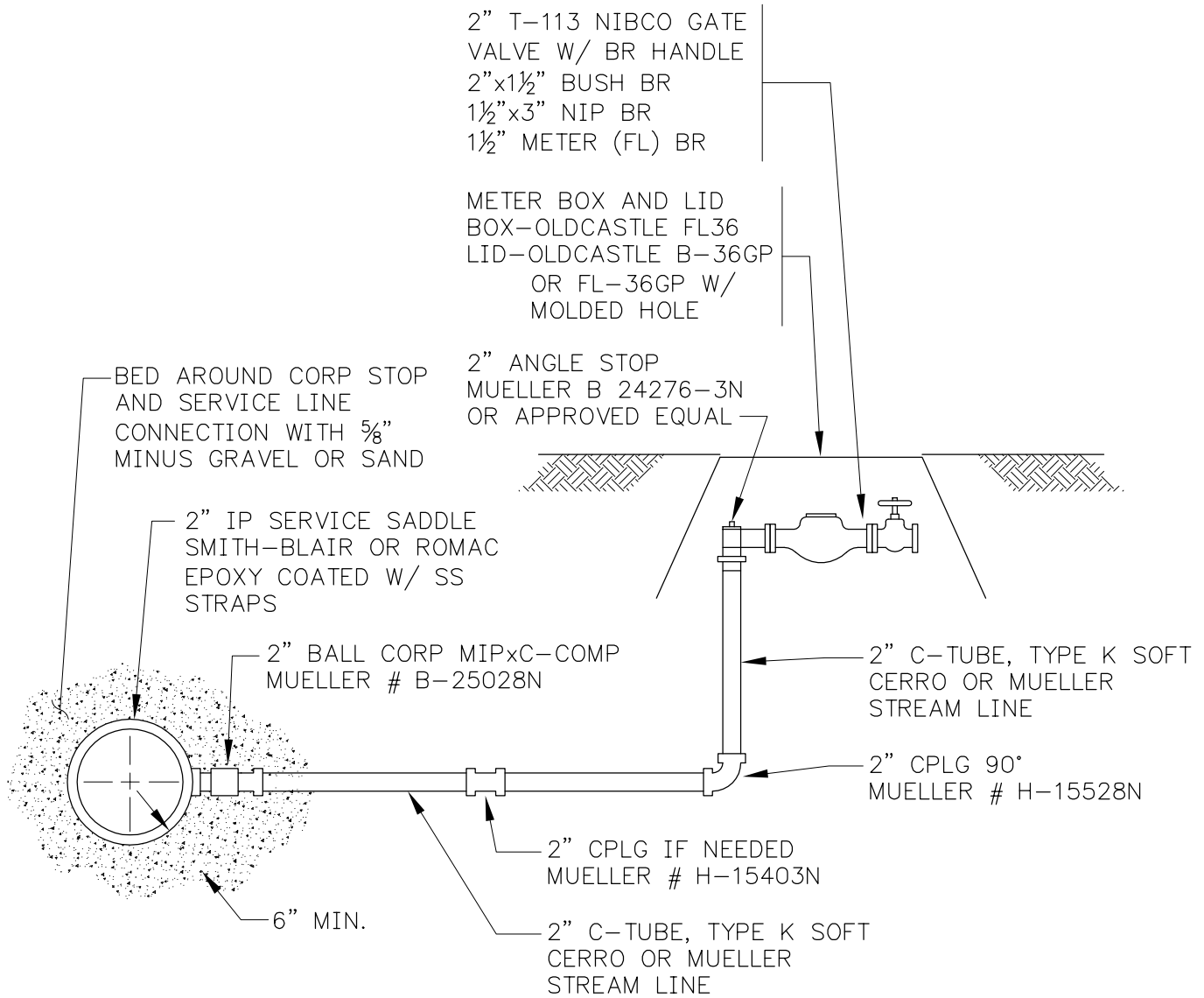

NOTES:

1. FURNISH AND INSTALL COPPER SERVICE LINE. FURNISH AND INSTALL CORPORATION AND ANGLE STOPS. FURNISH AND INSTALL CUSTOMER VALVE, METER BOX, AND LID. PROVIDE EXCAVATION AND BACKFILL.
2. FOR EXISTING SERVICES TO BE RECONNECTED TO NEW MAIN: INSTALL CORPORATION STOP.
3. ALL BRASS PARTS SHALL CONFORM TO THE NEW LOW LEAD RULE.

REVISED: 03/15

NCWD STANDARD DETAIL

NO. 9



1-1/2" SERVICE WITH METER SETTING



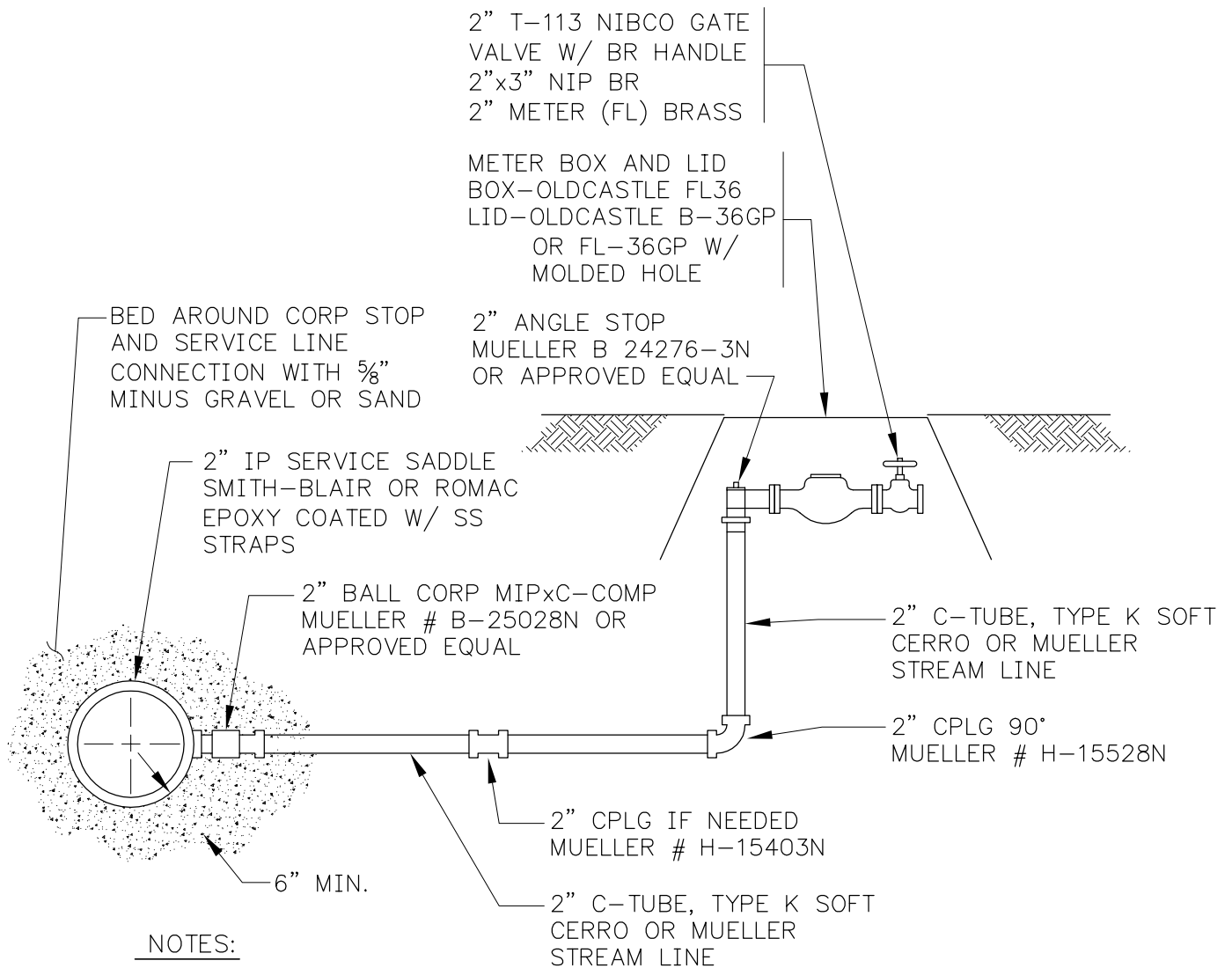

1. FURNISH AND INSTALL COPPER SERVICE LINE. FURNISH AND INSTALL CORPORATION AND ANGLE STOPS. FURNISH AND INSTALL CUSTOMER VALVE, METER BOX, AND LID. PROVIDE EXCAVATION AND BACKFILL.
2. FOR EXISTING SERVICES TO BE RECONNECTED TO NEW MAIN: INSTALL CORPORATION STOP.
3. ALL BRASS PARTS SHALL CONFORM TO THE NEW LOW LEAD RULE.

REVISED: 03/15

NCWD STANDARD DETAIL

NO. 10



2" SERVICE WITH METER SETTING



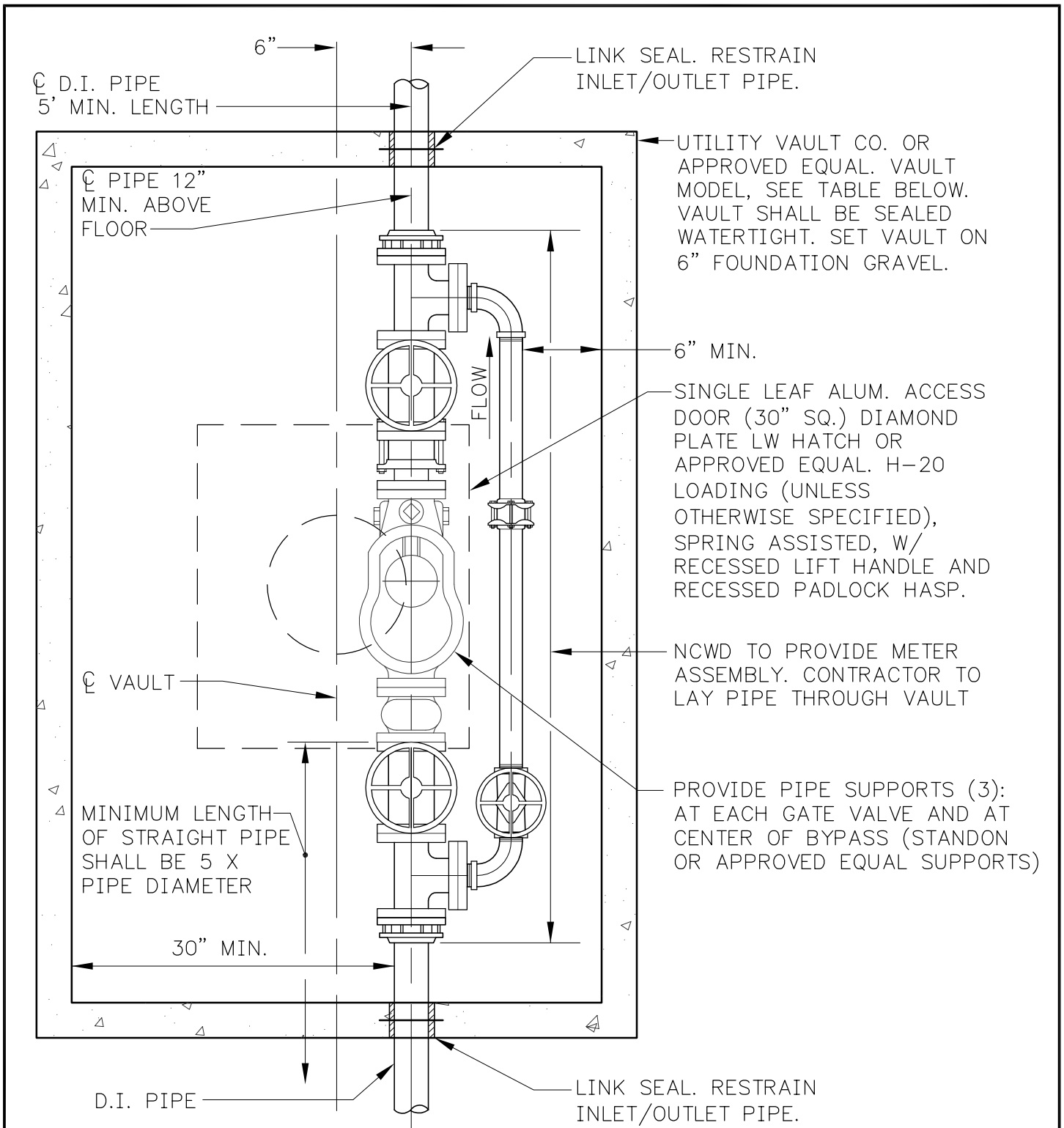

SIZE	MIN. VAULT SIZE (INSIDE)			UTIL. VAULT CO. MODEL
	W	L	H	
3"/4"	4'-6"	6'-11"	2'-8"	675 WA

REVISED: 03/15

NCWD STANDARD DETAIL

NO. 11



3" AND 4" WATER SERVICE

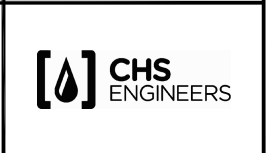

SURFACE RESTORATION IN ACCORDANCE WITH LOCAL JURISDICTIONAL REQUIREMENTS. MINIMUM REQUIREMENTS SHOWN IN TRENCH RESTORATION DETAIL.

BACKFILL PER JURISDICTIONAL REQUIREMENTS. COMPACT TO MIN. 95% MAX. DENSITY

BEDDING GRAVEL

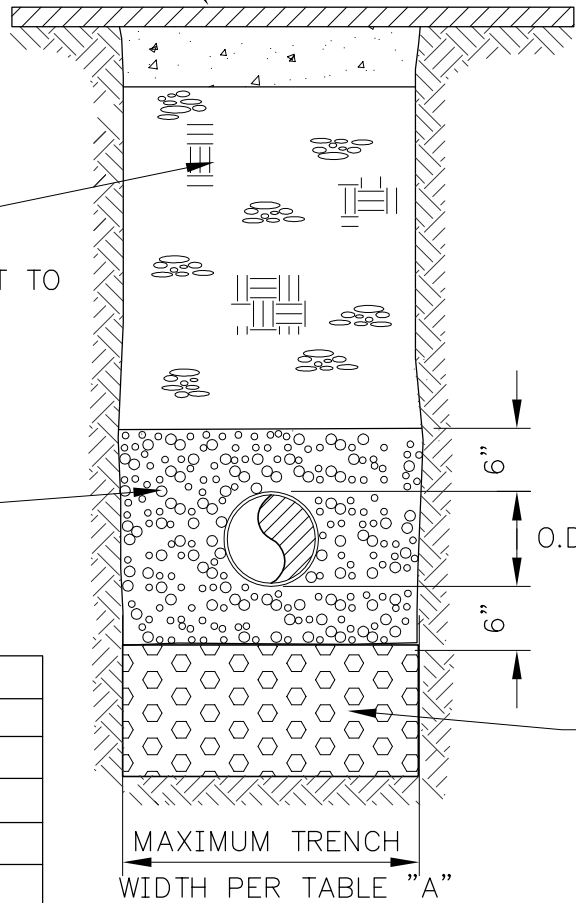

O.D. OF WATER MAIN

FOUNDATION GRAVEL (PER SPECIFICATIONS) AS REQUIRED BY DISTRICT

TABLE "A"

6" PIPE	2'-6"
8" PIPE	2'-6"
10" PIPE	3'-0"
12" PIPE	3'-0"
15",16" PIPE	3'-6"
18" PIPE	4'-0"
24" PIPE	4'-0"

TRENCH SECTION

NOTES:

1. FILL AREAS SHALL BE FILLED AND COMPACTED PRIOR TO INSTALLATION OF WATER MAINS. 95% COMPACTION PER ASTM D-1557 REQUIRED IN FILL AREAS. REPORTS REQUIRED PRIOR TO TRENCHING.
2. BEDDING SHALL BE 5/8" MINUS SURFACING.

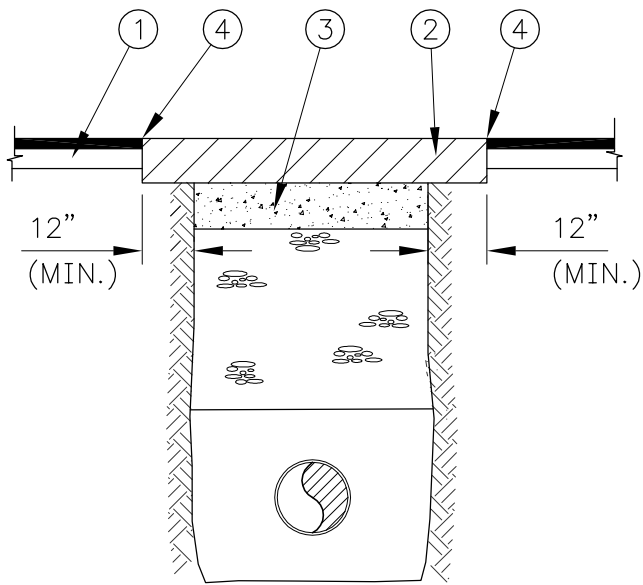

ASPHALT PAVEMENT RESTORATION

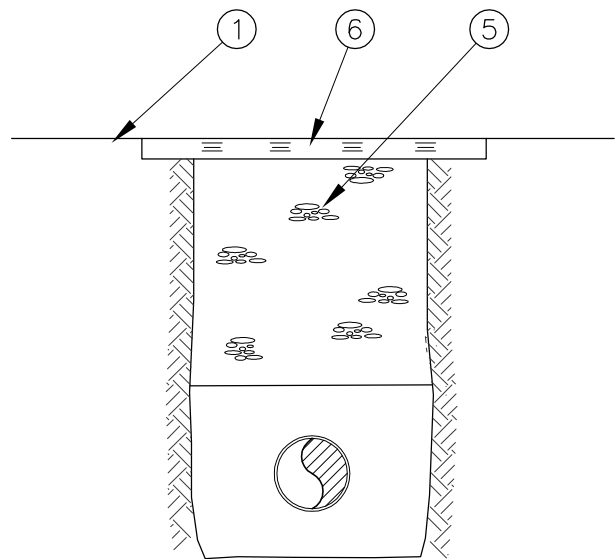



SHOULDER AND EASEMENT RESTORATION

NOTES:

- ① EXISTING SURFACE
- ② MATCH EXISTING ASPHALT DEPTH
- ③ CRUSHED GRAVEL PER LOCAL JURISDICTIONAL REQUIREMENTS.
- ④ SAW CUT. TACK EDGES WITH EMULSIFIED ASPHALT SEAM SEAL, AR4000.
- ⑤ TRENCH BACKFILL
- ⑥ RESTORE EXISTING SURFACE. TOP SOIL, SOD, 5/8" MINUS CRUSHED GRAVEL (2" MIN.) OR AS NOTED ON THE PLANS.

NOTE:

- 1. THESE STANDARDS ARE THE MINIMUM ALLOWABLE. LOCAL JURISDICTIONAL REQUIREMENTS SHALL OVERRIDE WHERE APPLICABLE.
- 2. SEE TYPICAL TRENCH SECTION DETAIL 12.

REVISED: 03/15	NCWD STANDARD DETAIL	NO. 13
	TRENCH SURFACE RESTORATION	

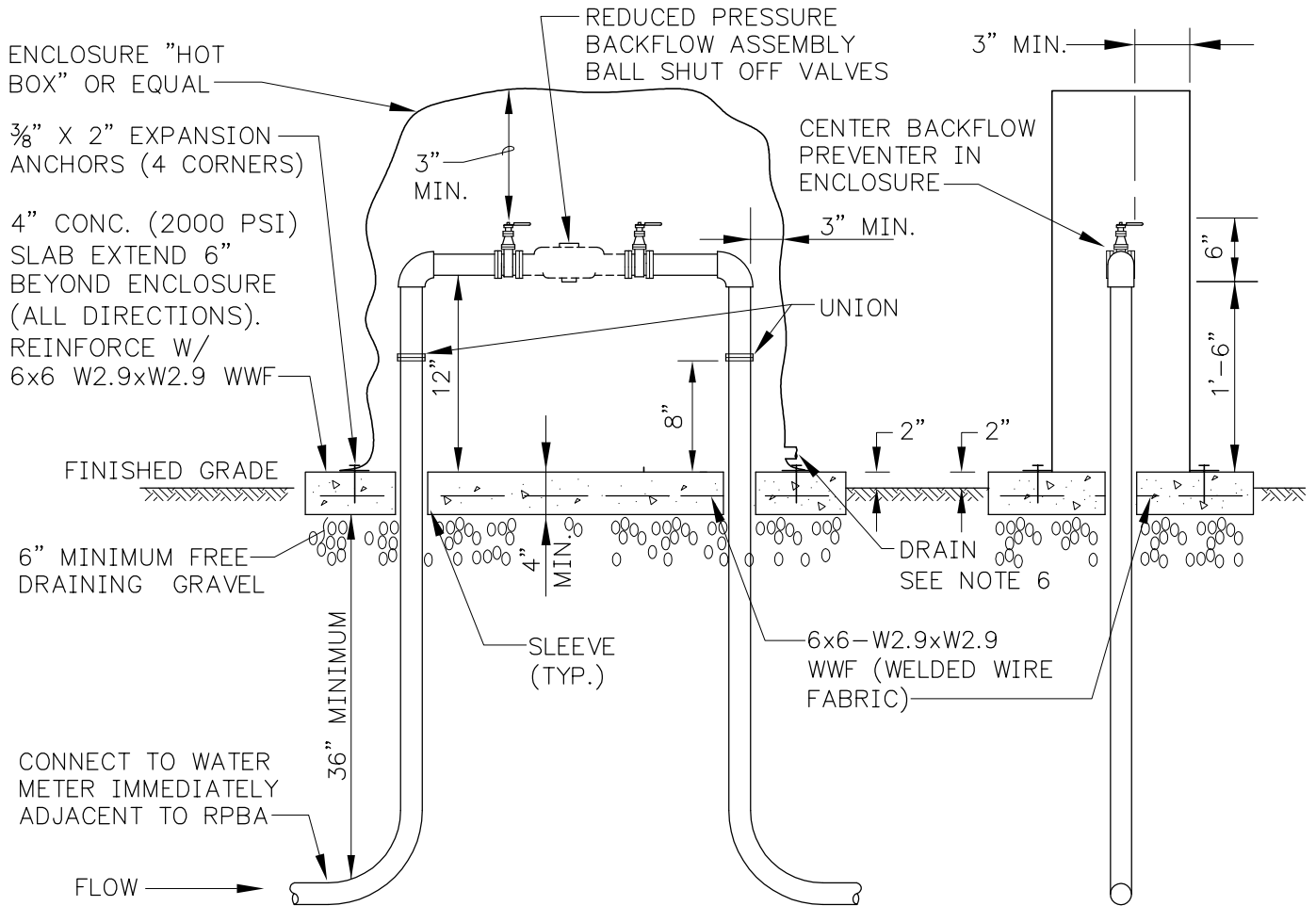

NOTES:

1. PROVIDE DISTRICT APPROVED SUPPORT FOR DEVICES LARGER THAN 1" DIAMETER.
2. OWNER SHALL FURNISH, INSTALL AND MAINTAIN THE RPBA AND ALL PIPING AND APPURTENANCES SHOWN ON THIS PLAN.
3. DISTRICT WILL PROVIDE INSPECTION OF THE RPBA PRIOR TO ESTABLISHMENT OF WATER SERVICE.
4. REDUCED PRESSURE BACKFLOW ASSEMBLIES SHALL BE STATE APPROVED DEVICES.
5. SUBSEQUENT ANNUAL TESTING AND REPORTING OF RPBA REQUIRED BY OWNER.
6. DRAIN SHALL BE SIZED IN ACCORDANCE WITH AWWA CROSS CONNECTION CONTROL MANUAL
7. HEAT TAPE IS RECOMMENDED ON DEVICE.

REVISED: 03/15

NCWD STANDARD DETAIL

NO. 14



**2" AND SMALLER
REDUCED PRESSURE
BACKFLOW ASSEMBLY**



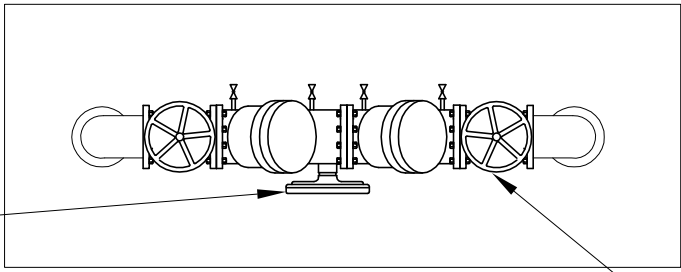

PLAN

CENTER RPBA IN BOTH DIRECTIONS OF BOX

HOT BOX INSTALLATION REQUIRED. CONTRACTOR TO VERIFY REQUIRED SIZE.

3' OR 4" 90° BEND (FL)

4" CONC. (2000 PSI) SLAB EXTEND 6" BEYOND ENCLOSURE (ALL DIRECTIONS). REINFORCE W/ 6x6 W2.9xW2.9 WWF

3/8" X 2" EXPANSION ANCHORS (4 CORNERS)

FINISHED GRADE

6" MINIMUM FREE DRAINING GRAVEL

4" D.I. CL 52 TO 3" OR 4" METER VAULT.

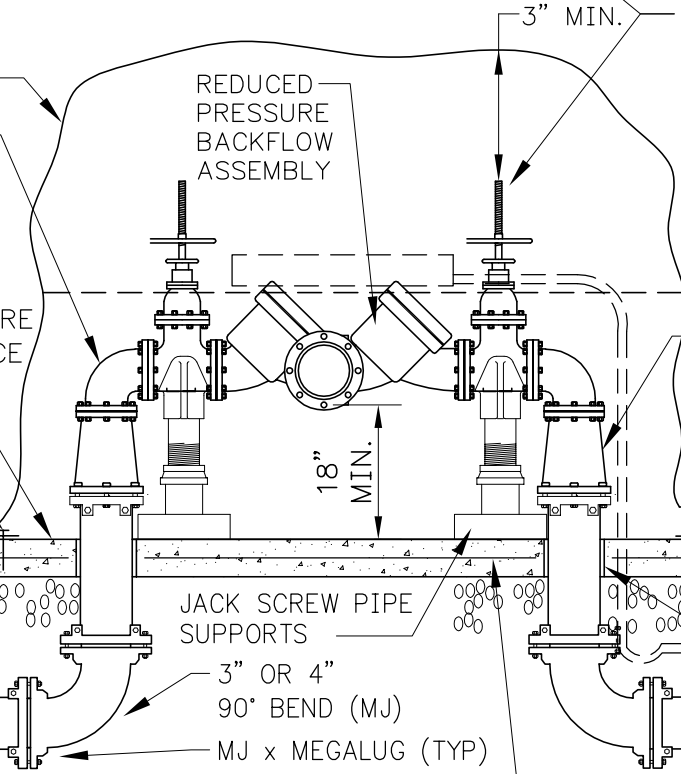

ELEVATION

3" MIN. RESILIENT WEDGE OS&Y GATE VALVES REQUIRED.

4"x3" REDUCER FOR 3" INSTALLATIONS.

DRAIN SEE NOTE 8

2"

PROVIDE 6" PVC SLEEVE THROUGH SLAB

18" MIN.

JACK SCREW PIPE SUPPORTS



3" OR 4" 90° BEND (MJ)

MJ x MEGALUG (TYP)

6x6-W2.9xW2.9 WWF (WELDED WIRE FABRIC)

NOTES:

1. APPROVED REDUCED PRESSURE BACKFLOW ASSEMBLY TO LAY HORIZONTAL ONLY.
2. DESIGNED FOR BACK SIPHONAGE AND BACK PRESSURE.
3. THE WATERLINE SHALL BE DISINFECTED, FLUSHED, AND PRESSURE TESTED PRIOR TO INSTALLING THE BACKFLOW ASSEMBLY. THE BACKFLOW ASSEMBLY SHALL BE PROTECTED FROM FREEZING AND FLOODING.
4. ALL FITTINGS SHALL BE FLANGED OR RESTRAINED.
5. LOCATION SHALL BE AS SHOWN ON THE DRAWINGS OR DIRECTED BY THE DISTRICT.
6. THE HOT BOX SHALL HAVE A MIN. CLEAR DISTANCE OF 3' FROM ALL OTHER STRUCTURES.
7. THE BACKFLOW ASSEMBLY SHALL BE STATE APPROVED AND TESTED AFTER INSTALLATION AND YEARLY THEREAFTER, BY A CERTIFIED BACKFLOW ASSEMBLY TESTER. TEST RESULTS SHALL BE SENT TO NORTH CITY WATER DISTRICT.
8. DRAIN SHALL BE SIZED IN ACCORDANCE WITH AWWA CROSS CONNECTION CONTROL MANUAL

REVISED: 03/15	NCWD STANDARD DETAIL	NO. 15
	2.5" AND LARGER REDUCED PRESSURE BACKFLOW ASSEMBLY	

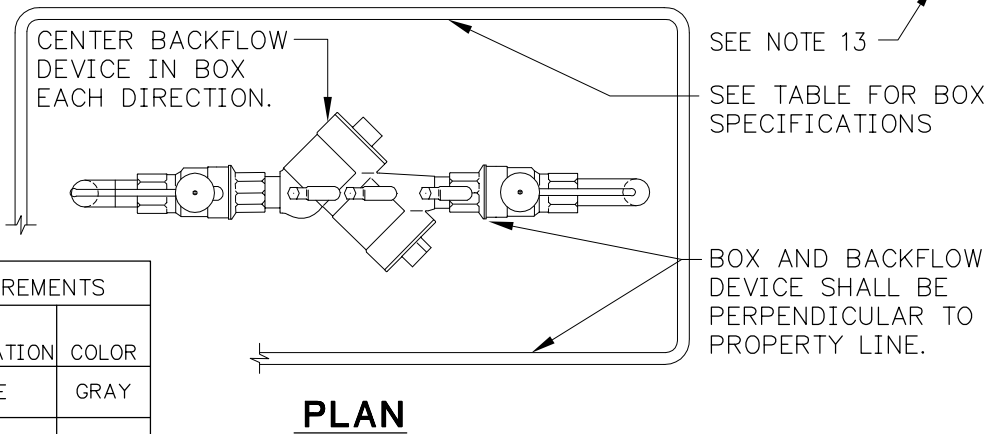
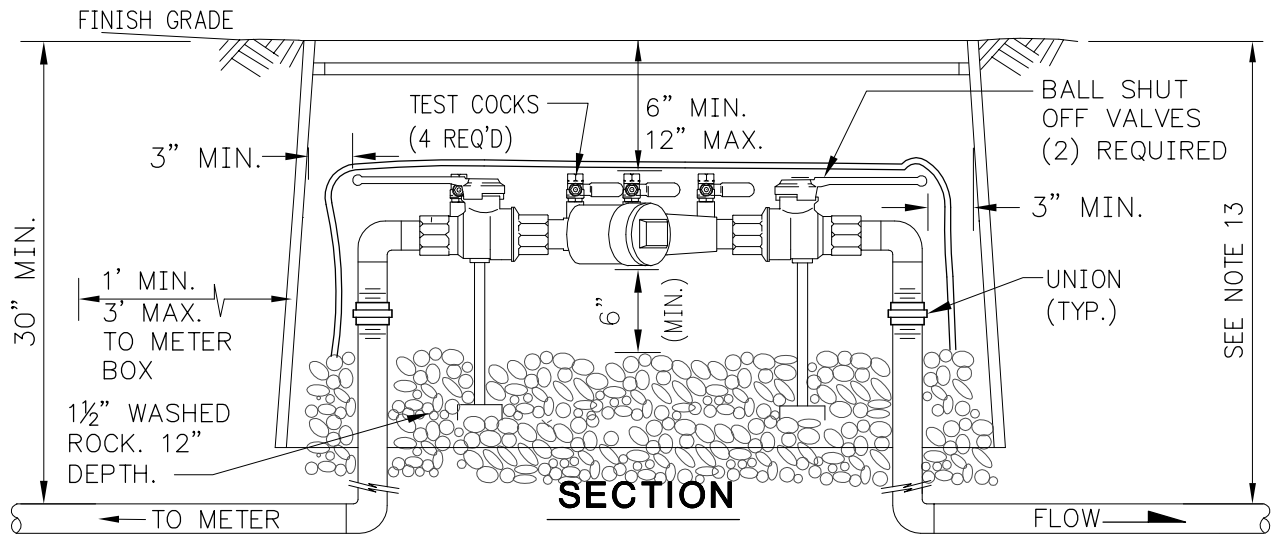

WATER BOX REQUIREMENTS			
SIZE	CARSON INDUSTRIES MODEL NO.	APPLICATION	COLOR
1" / 1 1/2"	1324-3B	FIRE	GRAY
1" / 1 1/2"	1324-3B	IRRIGATION	GREEN
2"	1730-3B	FIRE	GRAY
2"	1730-3B	IRRIGATION	GREEN

NOTES:

- CLEARANCES SHOWN ABOVE MUST BE MET OR BOX WILL NEED TO BE UP-SIZED.
- BOXES & LIDS SHALL BE EQUIPPED WITH THE BOLT DOWN FEATURE. DO NOT INSTALL READER FLAP.
- APPROVED DOUBLE CHECK VALVE ASSEMBLY TO BE INSTALLED HORIZONTAL WITH GROUND.
- DESIGNED FOR BACK SIPHONAGE, BACK PRESSURE AND LOW HEALTH HAZARDS.
- TEST COCKS TO EITHER FACE OUTWARDS OR UPWARDS FROM ASSEMBLY.
- THE DCVA MAY BE INSTALLED BELOW GROUND PROVIDED ALL OF THE CLEARANCES ARE MET.
- DO NOT INSTALL IN AN AREA SUBJECT TO FLOODING.
- DCVA MUST BE ACCESSIBLE.
- DCVA MUST BE PROTECTED FROM FREEZING CONDITIONS.
- THE BACKFLOW ASSEMBLY MUST BE A WASH. STATE APPROVED MODEL.
- DCVA MUST BE TESTED AFTER INSTALLATION AND YEARLY THEREAFTER BY A WASHINGTON STATE CERTIFIED BACKFLOW ASSEMBLY TESTER.
- TEST RESULTS SHALL BE SENT TO NORTH CITY WATER DISTRICT.
- FLUSH LINES PRIOR TO INSTALLATION OF BACKFLOW PREVENTER.
- COVER & TYPE OF PIPE FOR FIRELINES SHALL BE AS REQUIRED BY THE JURISDICTIONAL FIRE DISTRICT.

REVISED: 03/15

NCWD STANDARD DETAIL

NO. 16



**DOUBLE CHECK VALVE ASSEMBLY
2" AND SMALLER**



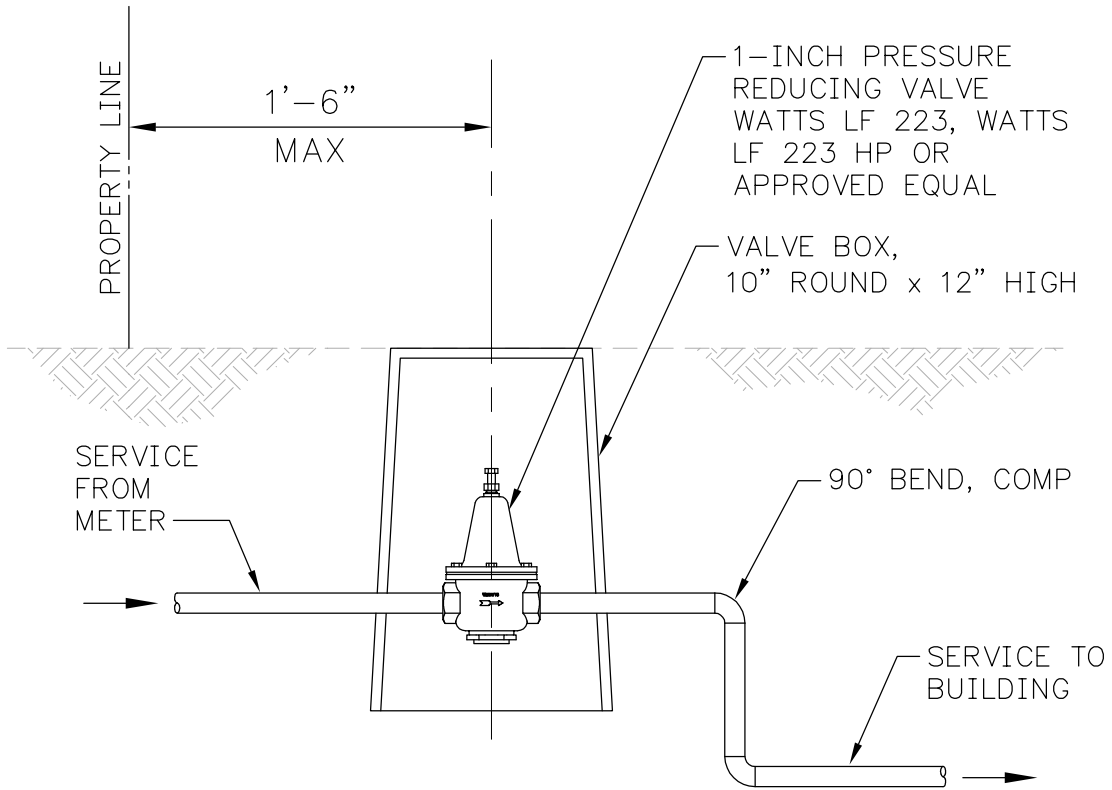

REVISED: 03/15

NCWD STANDARD DETAIL

NO. 17



RESIDENTIAL PRV



NOTES:

1. DISTRICT WILL DETERMINE IF REDUCED PRESSURE PRINCIPAL DEVICE IS REQUIRED.
2. ASSEMBLY TO BE MAINTAINED BY PROPERTY OWNER/CUSTOMER & ANNUAL CERTIFICATION REQUIRED.
3. FIRELINE SHALL NOT BE PUT INTO SERVICE UNTIL THE BACKFLOW PREVENTION ASSEMBLY IS APPROVED BY DISTRICT. CERTIFICATION FOLLOWING INSTALLATION REQUIRED.
4. TEE & GATE VALVE REQUIRED ON MAIN.
5. ALL CLEARANCES SHOWN ARE MINIMUM.
6. UL/FM METER REQUIRED IF POTABLE SERVICE ALSO PROVIDED FROM FIRE PROTECTION SERVICE LINE.

PLAN

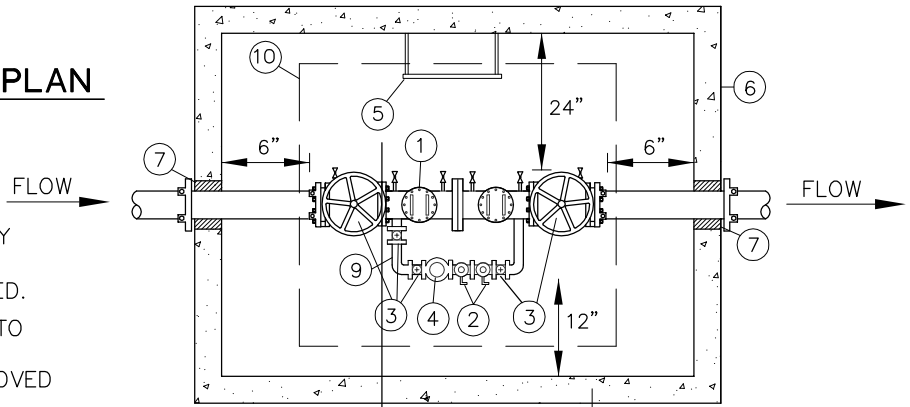

ELEVATION

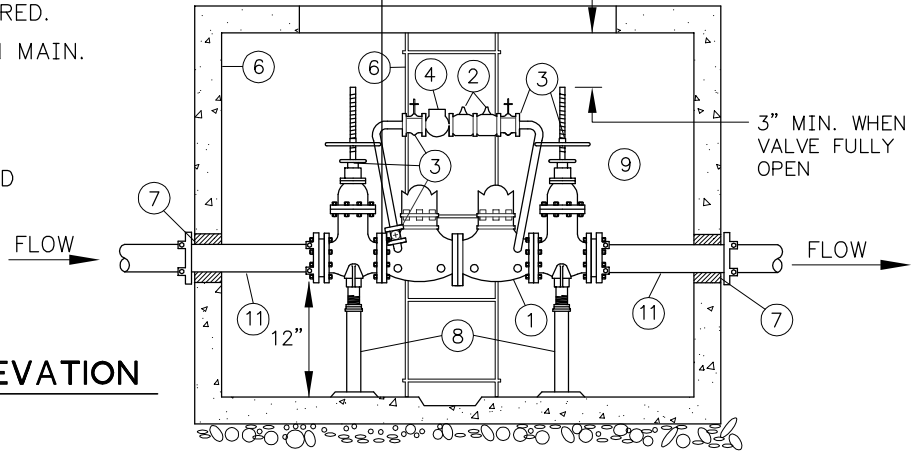

KEY NOTES:

- ① STATE APPROVED DOUBLE CHECK VALVE ASSEMBLY, COMPLETE W/ (4) RESILIENT SEATED TEST COCKS, & BRASS OR COPPER DETECTOR BY-PASS.
- ② STATE APPROVED 3/4" DOUBLE CHECK VALVE ASSEMBLY, COMPLETE W/ (4) RESILIENT SEATED TEST COCKS.
- ③ THE DEVICES MUST BE EQUIPPED WITH (2) RESILIENT WEDGE O.S.&Y. SHUT OFF GATE VALVES WITH HAND WHEELS. GATE VALVES SHALL CONFORM TO AWWA C-509 OR C515.
- ④ 5/8"x3/4" METER (CUBIC FEET READING)-SENSUS METER W/ TRPL.
- ⑤ ONE GALVANIZED STEEL LADDER TO BE SECURED TO VAULT FROM DOOR EDGE TO FLOOR.
- ⑥ CONCRETE VAULT W/ A MIN. 3'x6' DOUBLE LEAF ALUM. DIAMOND PLATE DOOR RATED FOR H2O LOADING, MARKED "WATER". DOORS SHALL BE LW HATCH OR EQUAL W/ SPRING LIFT & RECESSED PADLOCK HASP. PAINTED ALUM. SIGN TO BE MOUNTED ON UNDERSIDE OF HATCH "CONFINED SPACE. ENTRY BY PERMIT ONLY". VAULT SHALL BE EQUAL TO UTILITY VAULT CO. MODEL LISTED IN TABLE.
- ⑦ VAULT SHALL BE CORE DRILLED AND SEALED WITH LINK SEAL FOR MAINLINE PENETRATIONS. INSTALL MEGALUG RETAINER AND BRACE TO EDGE OF VAULT. WATER TIGHT GROUT SHALL BE USED IN ALL OTHER VAULT PENETRATIONS
- ⑧ TWO ADJUSTABLE PIPE STANDS REQUIRED.
- ⑨ ALL PLUMBING FOR BY-PASS TO BE COPPER OR BRASS.
- ⑩ ACCESS TO BE CENTERED OVER METER.
- ⑪ CLASS 52 DUCTILE IRON PIPE REQUIRED. SIZE AS REQUIRED. FOR 3", PLACE REDUCER OUTSIDE OF VAULT. ALL PIPE AND FITTINGS SHALL BE RESTRAINED.

SIZE	MIN. VAULT SIZE (INSIDE)			UTIL. VAULT CO MODEL
	W	L	H	
3"	5'-6"	7'-0"	4'-5"	675-WA
4"	5'-6"	7'-0"	4'-5"	675-WA
6"	5'-6"	7'-0"	4'-5"	675-WA
8"	5'-0"	10'-6"	6'-0"	5106-LA
10"	5'-0"	10'-6"	6'-0"	5106-LA

REVISED: 03/15

NCWD STANDARD DETAIL

NO. 18



DOUBLE CHECK DETECTOR ASSEMBLY



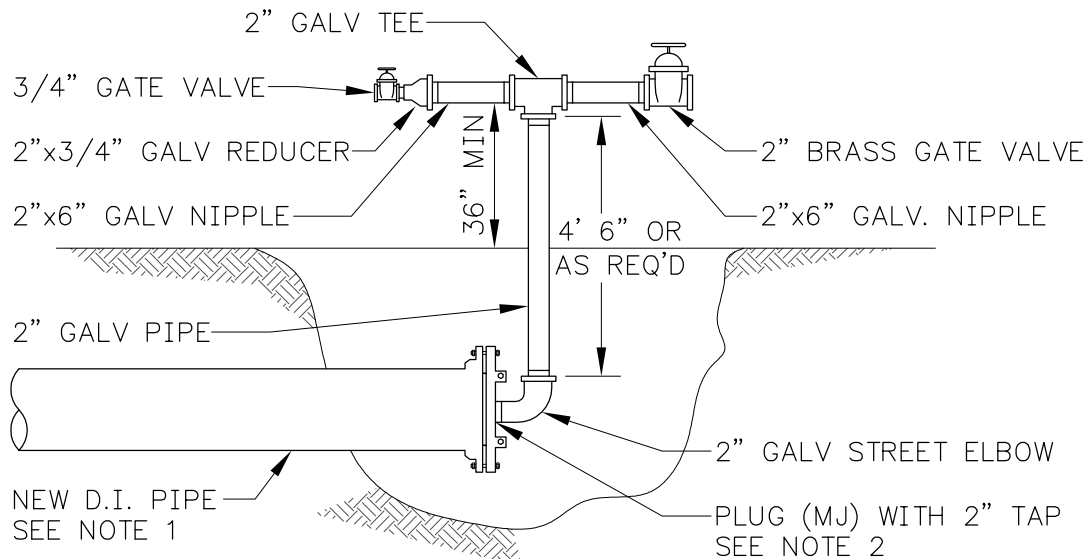

2" SAMPLE TREE

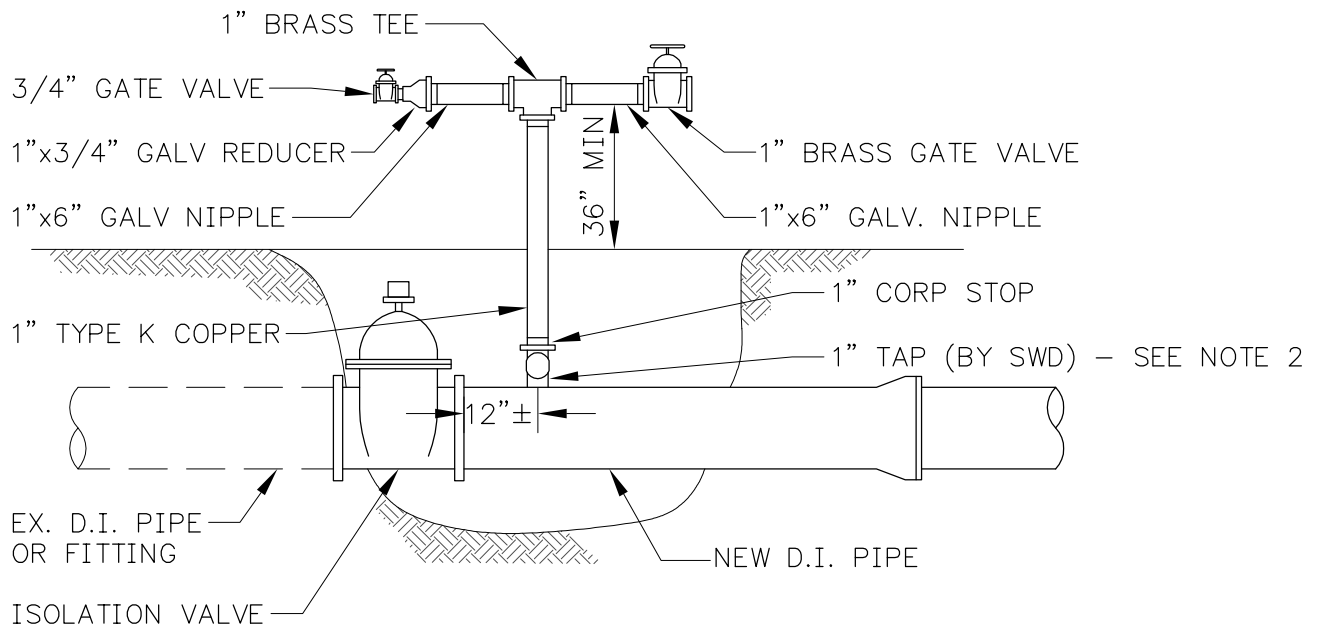

1" DISINFECTION TREE

NOTES:

1. AT A MINIMUM, RESTRAIN THE LAST THREE FULL PIPE LENGTHS FOR 4", 6", AND 8" PIPE. RESTRAIN THE LAST FIVE FULL PIPE LENGTHS FOR 12" PIPE.
2. UPON COMPLETION OF REQUIRED TESTS AND AFTER CONFIRMATION OF SAMPLE RESULTS, CONTRACTOR TO REMOVE TREE ASSEMBLY IN PRESENCE OF NCWD INSPECTOR. NCWD TO PROVIDE EITHER 2" BRASS OR 1" BRASS PLUG.
3. BACKFILL WITH GRAVEL BEDDING IN PIPE ZONE AND CRUSHED SURFACING TOP COURSE IN REMAINING TRENCH.

REVISED: 03/15

NCWD STANDARD DETAIL

NO. 20



1" AND 2" TESTING TREES



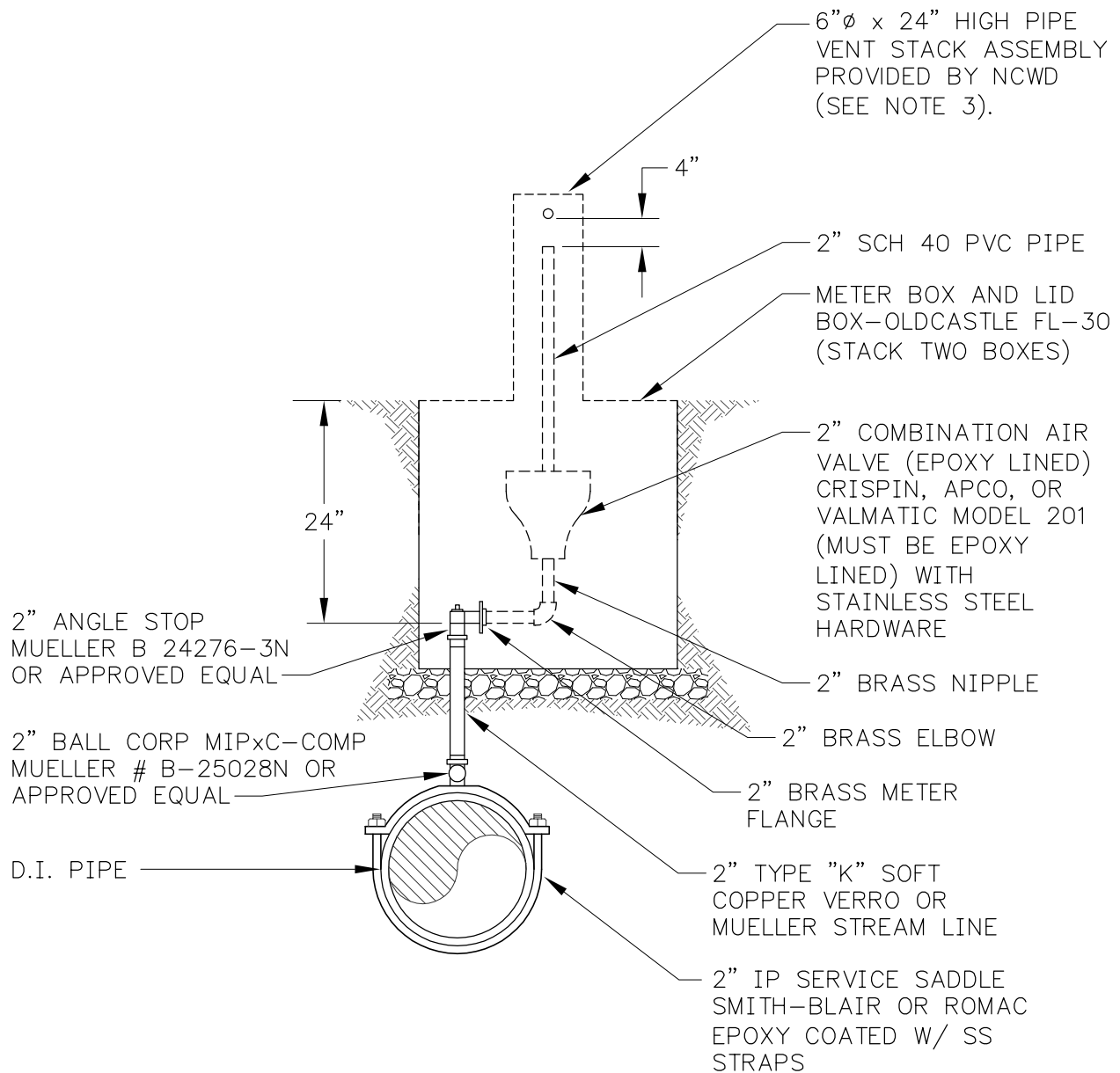

NOTE:

1. CRISPIN A111145 UL10, VAL-MATIC 201.C.2 SV OR APPROVED EQUAL.

REVISED: 03/15

NCWD STANDARD DETAIL

NO. 22



2" AIR VALVE



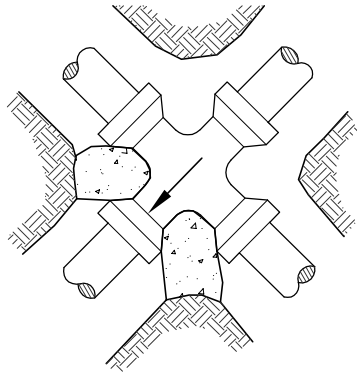

UNBALANCED CROSS

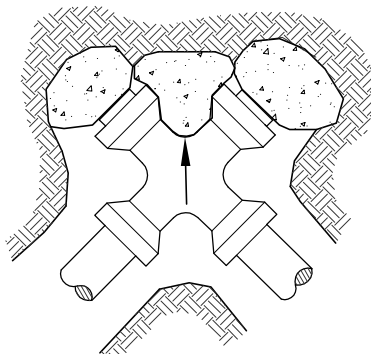

PLUGGED CROSS

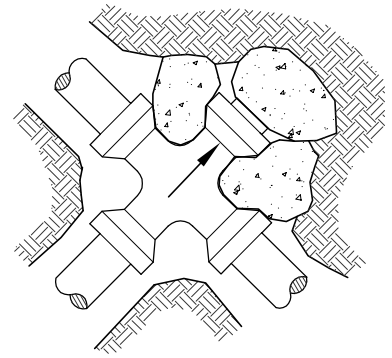

PLUGGED CROSS

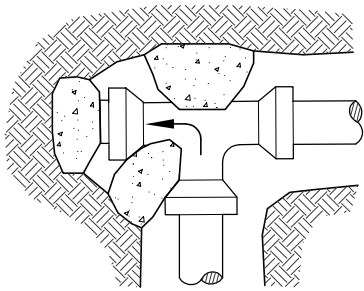

PLUGGED TEE

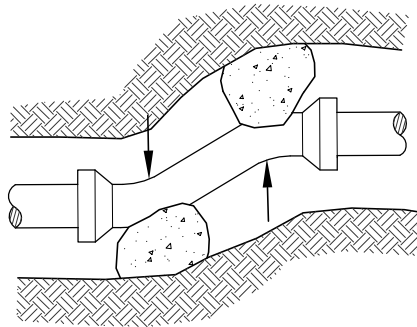

OFFSET

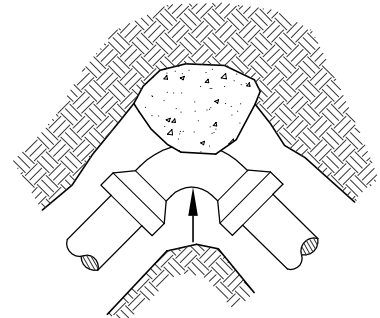

HORIZONTAL BEND

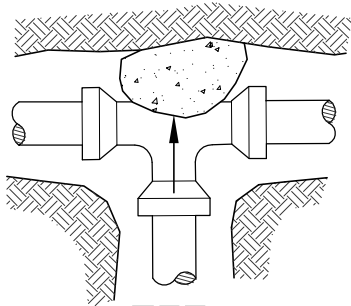

TEE

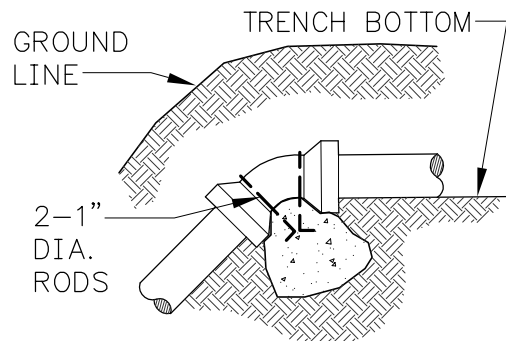

VERTICAL BEND

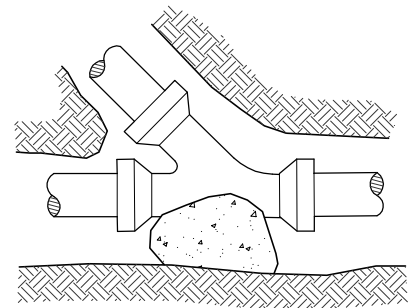

"Y" BRANCH

NOTES:

1. SIZE OF BLOCK TO BE DETERMINED BY THE CONTRACTOR, TO BE ADEQUATE FOR SOIL CONDITIONS AND PRESSURE INVOLVED.
2. ALL BLOCKING TO BE ON UNDISTURBED MATERIAL.
3. PLUGS TO BE BLOCKED IF NOT SECURED BY BOLTING OR ADEQUATE STRAPS.

REVISED: 03/15

NCWD STANDARD DETAIL

NO. 23



CONCRETE THRUST BLOCKING



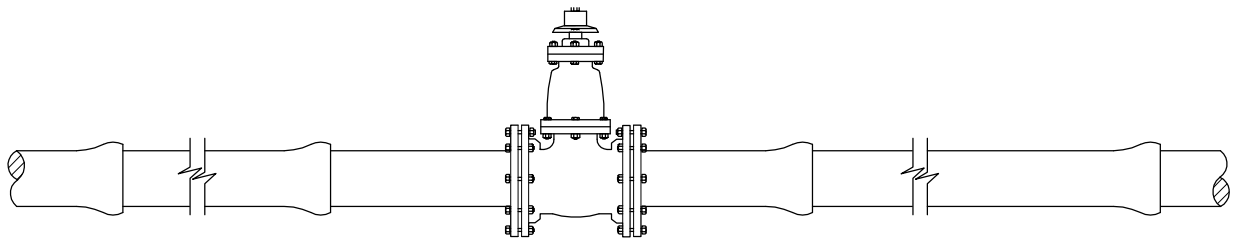

IN-LINE VALVE

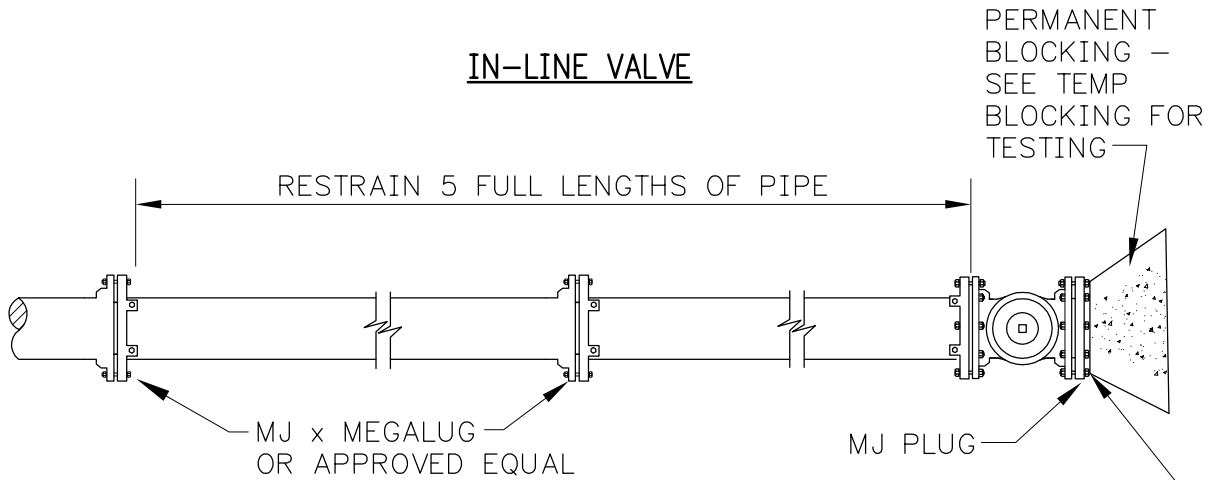

DEAD END PLAN

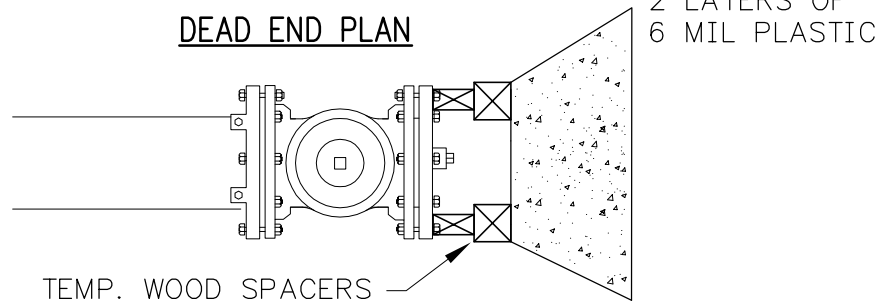

TEMPORARY BLOCKING

NOTES:

1. THRUST BLOCKING REQUIRED – SEE NCWD STANDARD THRUST REQUIREMENTS DETAIL.
2. ADDITIONAL RESTRAINT IS REQUIRED ON DEAD ENDS WITH POOR GROUND CONDITIONS.
3. MEGALUGS (EBAA IRON OR APPROVED EQUAL) SHALL BE INSTALLED ON ALL INDICATED MECHANICAL JOINTS.
4. SEE STANDARD PLAN FOR BEND BLOCKING REQUIREMENTS.
5. CLOW, AFC, AVK, M&H, KENNEDY, MUELLER ARE ACCEPTABLE RESILIENT SEAT VALVES.
6. ALL BOLTS SHALL BE TRI-PAC 2000 BLUE.

REVISED: 03/15	NCWD STANDARD DETAIL	NO. 24
	VALVES AND RESTRAINT REQUIREMENTS	

MECHANICAL JOINT PIPE FITTINGS

SIZE OF PIPE (DIA.)	MAX DEFLECTIONS IN INCHES PER LENGTH				MIN RADIUS OF CURVE FOR SUCCESSIVE DEFLECTION			
	FOR PIPE LENGTHS OF				FOR PIPE LENGTHS OF			
	12FT	16FT	18FT	20FT	12FT	16FT	18FT	20FT
3"	16"	23"	25"	27"	105'	130'	155'	180'
4"	16"	23"	25"	27"	105'	130'	155'	180'
6"	14"	19"	22"	24"	120'	160'	175'	200'
8"	11"	14"	16"	18"	160'	220'	240'	265'
10"	11"	14"	16"	18"	160'	220'	240'	265'
12"	11"	14"	16"	18"	160'	220'	240'	265'
14"	7"	10"	11"	12"	250'	310'	350'	400'
16"	7"	10"	11"	12"	250'	310'	350'	400'
18"	6"	8"	9"	10"	290'	380'	430'	480'
20"	6"	8"	9"	10"	290'	380'	430'	480'
24"	5"	7"	7"	8"	350'	440'	555'	600'
30"	5"	7"	7"	8"	350'	440'	555'	600'
36"	4"	6"	6"	7"	430'	510'	650'	690'

PUSH IN PIPE FITTINGS

SIZE OF PIPE (DIA.)	MAX DEFLECTIONS IN INCHES PER LENGTH				MIN RADIUS OF CURVE FOR SUCCESSIVE DEFLECTION			
	FOR PIPE LENGTHS OF				FOR PIPE LENGTHS OF			
	12FT	16FT	18FT	20FT	12FT	16FT	18FT	20FT
3"	10"	14"	15"	17"	175'	220'	260'	280'
4"	10"	14"	15"	17"	175'	220'	260'	280'
6"	10"	14"	15"	17"	175'	220'	260'	280'
8"	10"	14"	15"	17"	175'	220'	260'	280'
10"	10"	14"	15"	17"	175'	220'	260'	280'
12"	10"	14"	15"	17"	175'	220'	260'	280'
14"	6"	8"	9"	10"	290'	380'	430'	480'
16"	6"	8"	9"	10"	290'	380'	430'	480'
18"	6"	8"	9"	10"	290'	380'	430'	480'
20"	6"	8"	9"	10"	290'	380'	430'	480'
24"	6"	8"	9"	10"	290'	380'	430'	480'
30"	4"	5"	6"	7"	430'	615'	650'	690'
36"	4"	5"	6"	7"	430'	615'	650'	690'

NOTES:

- VALUES LISTED IN THESE TABLES ARE NOT INTENDED TO SUPERSEDE THE MANUFACTURER'S OR AWWA'S RECOMMENDED MAXIMUM DEFLECTION VALUES. IN CASES OF CONFLICT BETWEEN THE LISTED CALUES AND THE MANUFACTURER'S OR AWWA'S VALUES, THE MANUFACTURER'S OR AWWA'S VALUES MAY BE SUBSTITUTED AS LONG AS THIS CHANGE IS APPROVED BY THE DISTRICT.
- INSTALLATION OF THE PIPE ON A CURVE SHALL FOLLOW THE MANUFACTURER'S OR AWWA'S INSTALLATION PROCEDURE.

REVISED: 03/15	NCWD STANDARD DETAIL	NO. 26
	MAXIMUM PERMISSIBLE DEFLECTION PRESSURIZED DUCTILE IRON PIPE	

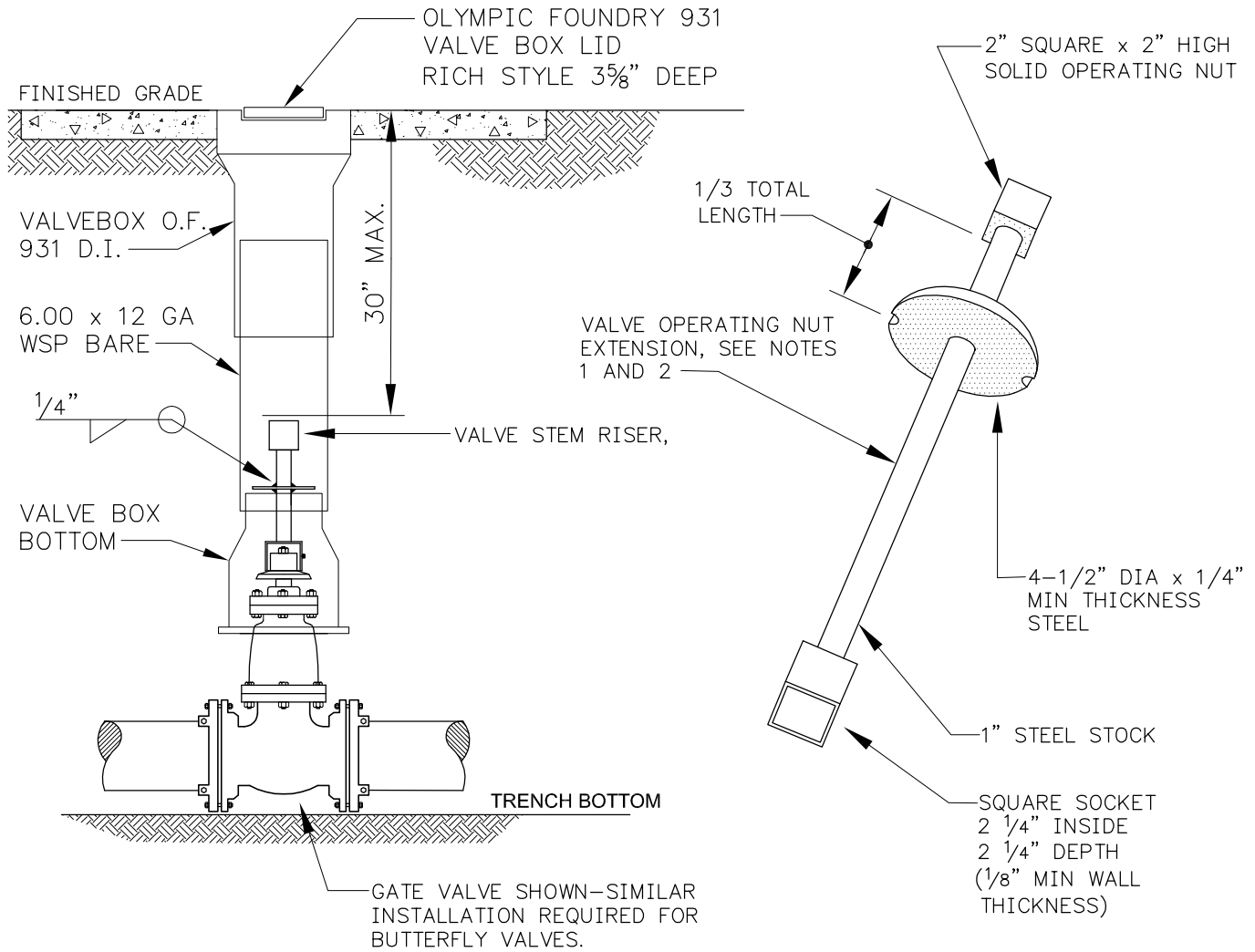

NOTES:

1. VALVE OPERATING NUT EXTENSIONS ARE REQUIRED WHEN THE VALVE NUT IS MORE THAN 30 INCHES BELOW FINISHED GRADE. EXTENSIONS ARE TO BE A MINIMUM OF ONE (1) FOOT LONG. ONLY ONE EXTENSION WILL BE ALLOWED PER VALVE.
2. ALL VALVE OPERATING NUT EXTENSIONS ARE TO BE MADE OF STEEL, SIZED AS NOTED.

REVISED: 03/15

NCWD STANDARD DETAIL

NO. 27



VALVE OPERATING NUT EXTENSION



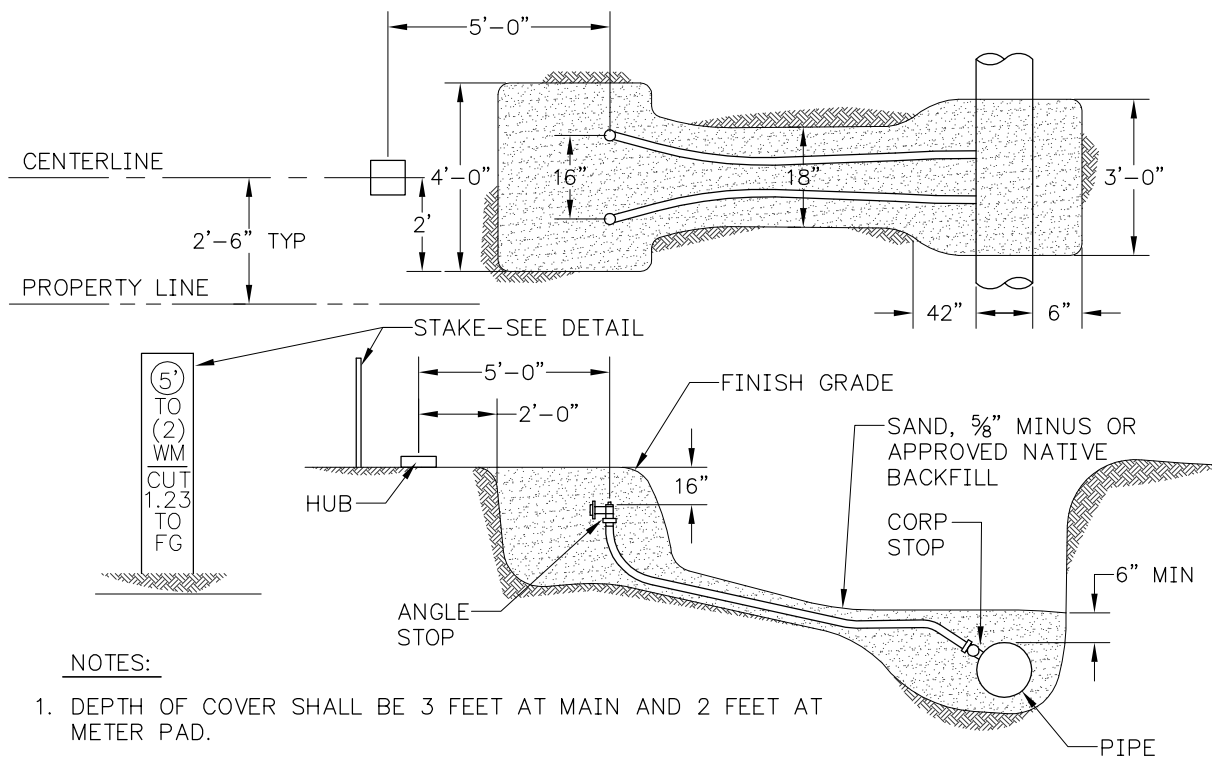

NOTES:

1. DEPTH OF COVER SHALL BE 3 FEET AT MAIN AND 2 FEET AT METER PAD.
2. WATER METER STAKE INFORMATION SHALL INCLUDE 1) OFFSET DISTANCE, 2) NUMBER OF SERVICE METERS, AND 3) CUT OR FILL TO FINISH GRADE.

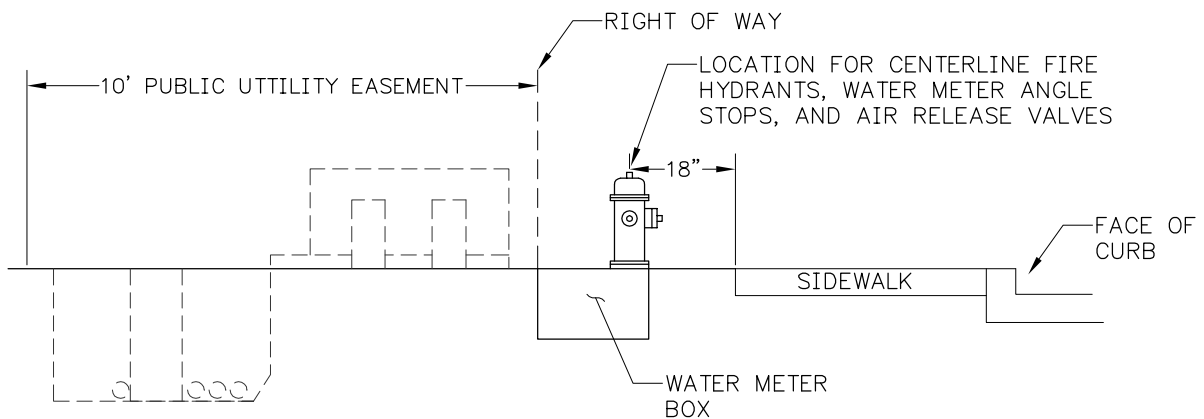

NOTES:

1. IF PARKWAY SITUATION, THEN LOCATE 2' FROM FRONT EDGE OF SIDEWALK.
2. IF RIGHT-OF-WAY/STREET WIDTHS PRECLUDE FIRE HYDRANTS, WATER METERS, AND AIR RELEASE VALVES FROM BEING WITHIN RIGHT-OF-WAY, THEN DESIGN ENGINEER/SURVEYOR/ DEVELOPER SHALL CONFIRM LOCATIONS WITH SWD.

REVISED: 03/15

NCWD STANDARD DETAIL

NO. 28



METER INSTALLATION AND LOCATION



WATER MAIN STANDARD PIPE MATERIAL FOR SEWER LINES

TYPE OF PIPE	AWWA (ASTM) STANDARD		
	PIPE	JOINT	FITTINGS
DUCTILE IRON	C 151 AND C 104	C 111	C 110
ASBESTOS CEMENT	C 400 TYPE II	D 1869	C 110
POLYVINYL-CHLORIDE	C900	D3139 AND F 477	C 110
CONCRETE CYLINDER	C303		

"CRITERIA FOR SEWAGE WORKS DESIGN"
REFER DOE LATEST EDITION C1-9.1

NO SEWER ALLOWED
IN THIS AREA

WATER MAIN STANDARD
PIPE MATERIAL FOR SEWER
LINES (SEE TABLE)

STANDARD SEWER
PIPE MATERIAL

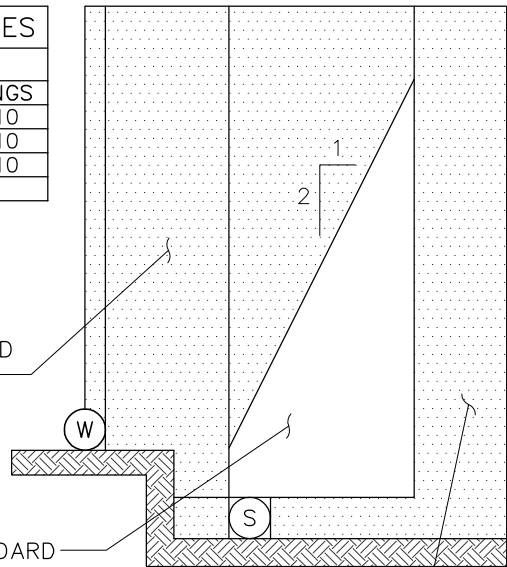

HORIZONTAL SEPARATION NOTES
(FOR PARALLEL CONSTRUCTION)

THE PARALLEL SEPARATION DETAIL ON THIS SHEET REFERS TO GRAVITY SEWERS ONLY. PRESSURE SEWERS SHALL ONLY BE CONSTRUCTED UNDER WATER MAINS WITH A MINIMUM CLEARANCE OF 18" FROM THE BOTTOM OF THE WATER MAIN TO THE TOP OF THE PRESSURE SEWER LINE.

VERTICAL SEPARATION NOTES
(FOR PERPENDICULAR CONSTRUCTION)

SEWER LINES CROSSING WATER LINES SHALL BE LAID BELOW THE WATER LINES TO PROVIDE A SEPARATION OF AT LEAST 18" BETWEEN THE INVERT OF THE WATER PIPE AND THE CROWN OF THE SEWER, WHENEVER POSSIBLE. WHEN LOCAL CONDITIONS PREVENT THIS VERTICAL SEPARATION, THE FOLLOWING CONSTRUCTION SHALL BE USED:

A. GRAVITY SEWERS PASSING OVER OR UNDER WATER LINES SHALL BE:

1. CONSTRUCTED OF WATER MAIN STANDARD PIPE MATERIAL AS SHOWN IN THE TABLE. THE ONE SEGMENT OF THE MAXIMUM STANDARD LENGTH OF PIPE (BUT NO LESS THAN 18' LONG) SHALL BE USED WITH THE PIPES CENTERED TO MAXIMIZE JOINT SEPARATION.
2. STANDARD GRAVITY SEWER MATERIAL ENCASED IN CONCRETE OR IN A ¼" THICK CONTINUOUS STEEL CASING WITH ALL VOIDS PRESSURE - GROUTED WITH SAND - CEMENT GROUT. THE LENGTH OF SEWER PIPE SHALL BE CENTERED AT THE POINT OF CROSSING SO THE JOINTS WILL BE EQUI-DISTANT AND AS FAR AS POSSIBLE FROM THE WATER LINE. THE SEWER PIPE SHALL BE THE LONGEST STANDARD LENGTH AVAILABLE FROM THE MANUFACTURER.

B. WATER LINES PASSING UNDER GRAVITY SEWER, IN ADDITION, SHALL BE PROTECTED BY PROVIDING:

1. A VERTICAL SEPARATION OF AT LEAST 18 INCHES BETWEEN THE INVERT OF THE SEWER AND THE CROWN OF THE WATER LINE;
2. ADEQUATE STRUCTURAL SUPPORT FOR THE SEWERS TO PREVENT EXCESSIVE DEFLECTION OF JOINTS AND SETTLING ON AND BREAKING OF THE WATER LINES.

C. PRESSURE SEWERS SHALL ONLY BE CONSTRUCTED UNDER WATER LINES AND DUCTILE IRON PIPE OR STANDARD SEWER PIPE IN A STEEL CASING FOR A MINIMUM DISTANCE OF AT LEAST TEN (10) FEET ON EACH SIDE OF THE CROSSING.

REVISED: 03/15

NCWD STANDARD DETAIL

NO. 29



WATER AND SEWER SEPARATION



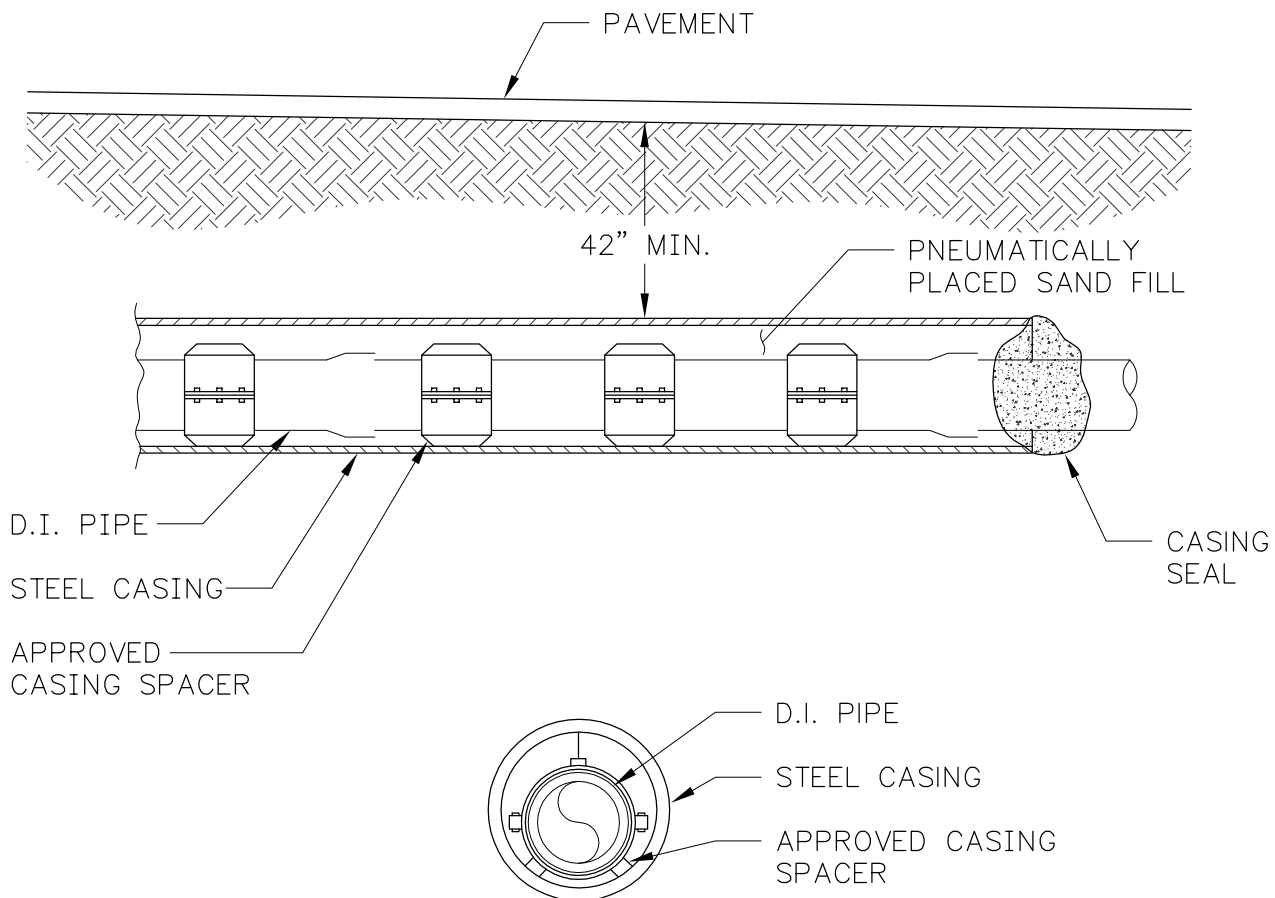

NOTES:

1. CASING SIZE AND MINIMUM THICKNESS OF CASING SHALL BE AS SHOWN ON THE CONTRACT DRAWINGS. HOWEVER, THE CONTRACTOR SHALL BE RESPONSIBLE FOR SELECTING THE THICKNESS CONSISTENT WITH HIS OPERATION.
2. SEAL CASING BOTH ENDS.

REVISED: 03/15	NCWD STANDARD DETAIL	NO. 30
	TYPICAL CASING PROFILE	

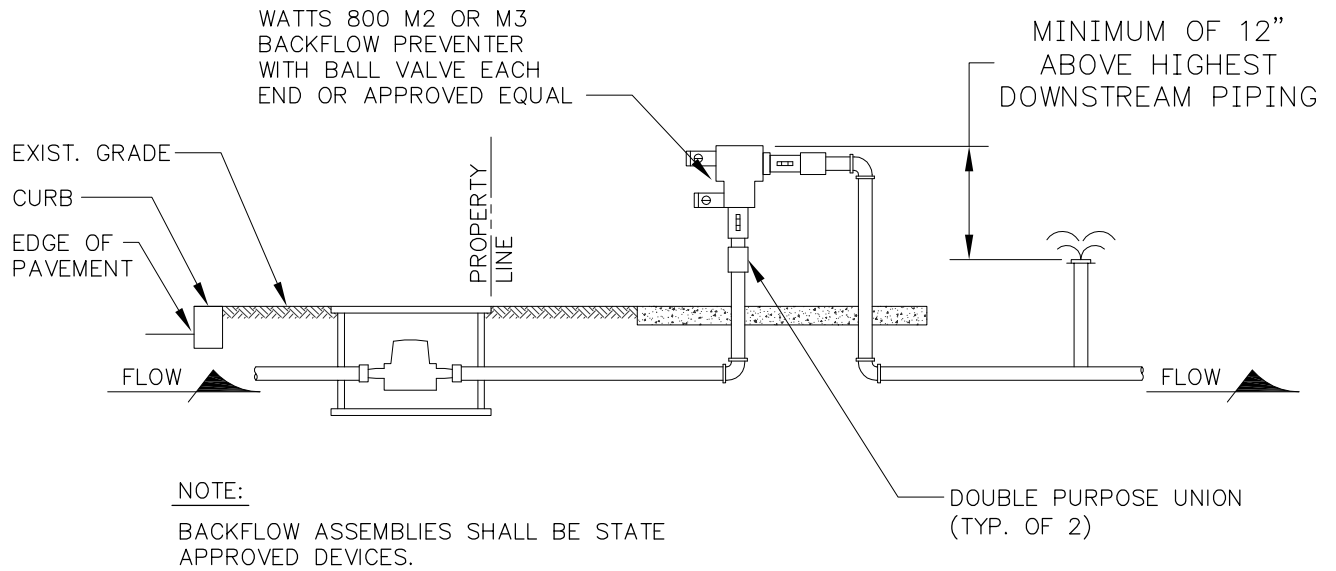

PRESSURE VACUUM BREAKER ASSEMBLY (PVBA) OR
SPILL-RESISTANT PRESSURE VACUUM BREAKER
ASSEMBLY (SVBA) INSTALLATION

REVISED: 03/15

NCWD STANDARD DETAIL

NO. 31



**PVBA/SVBA
BACKFLOW PREVENTERS**

